

SPRINKLER HEAD

BRAND	:	VIKING
MANUFACTURER	:	VIKING CORPORATION
COUNTRY	:	USA.
MODEL	:	VK1001
TYPE	:	UPRIGHT
RESPONSE	:	STANDARD RESPONSE
APPROVED	:	UL/FM
K-FACTOR	:	5.6 GPM/PSI^{1/2}
CONNECTION	:	SCREWED ENDS
TEMP.	:	135°F / 155°F / 175°F / 200°F / 286°F
PRESSURE	:	250 PSI. WKP. (UL LISTED) 175 PSI. WKP. (FM APPROVED)

MATERIAL LIST

FRAME	:	BRASS
BULB	:	GLASS 5 MM.
BELLEVILLE SPRING	:	NICKEL ALLOY
DEFLECTOR	:	STAINLESS STEEL



TECHNICAL DATA SHEET

VK1001 Standard Response Upright Sprinkler K5.6 (80.6)

1. PRODUCT IDENTIFICATION

This document covers the following product, hereafter referred to as “sprinkler”:

VK1001: Standard Response, Standard Coverage, Upright, K5.6 (80.6) Sprinkler.

2. INTENDED USE

The sprinkler is intended to be used in automatic fire sprinkler systems as allowed by applicable approval authorities. The sprinkler must be used in accordance with:

1. the sprinkler’s Listings, Approvals, and associated design requirements.
2. the recognized design and installations standards issued, for example NFPA, FM, EN, VdS, or LPCB.
3. the latest revisions of all applicable manufacturer’s documentation.



Governmental codes, ordinances, and standards may apply and may differ from one another.

WARNING

Cancer and Reproductive Harm www.P65Warnings.ca.gov

3. LISTING AND APPROVALS

Refer to section 5 for details and requirements that must be followed.



4. TECHNICAL SPECIFICATIONS

4.1 Definitions

Standard Upright Sprinkler: A sprinkler intended to be oriented with the deflector above the frame so water flows upward through the orifice, striking the deflector and forming an umbrella-shaped spray pattern downward. These sprinklers are marked “SSU” (Standard Spray Upright) or “UPRIGHT” on the deflector.

Corrosion Resistant Sprinkler: A special service sprinkler with non-corrosive protective coatings, or that is fabricated from non-corrosive material, for use in atmospheres that would normally corrode sprinklers. Standard sprinklers can be ordered as corrosion resistant sprinklers and can be used with escutcheons when allowed by the approval body.

4.2 Ratings and Physical Characteristics

Parameter	Value
Minimum operating pressure	7 psi (0.5 bar)
Maximum rated pressure	UL: 250 psi (17 bar) FM and CE: 175 psi (12 bar)
Factory tested pressure	500 psi (35 bar)
Thread size	1/2" NPT or 15 mm BSPT
Nominal K-factor	5.6 U.S. (80.6)
Minimum temperature rating (glass bulb)	-65 °F (-55 °C)

4.3 Markings and Dimensions

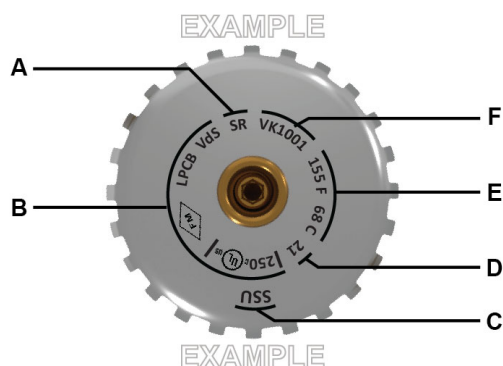

Figure – 1: Markings

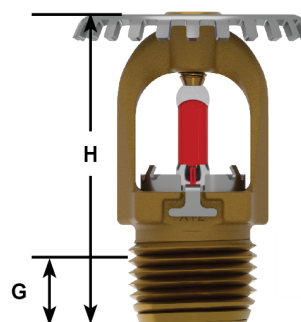

Figure – 2: Dimensions

Ref	Description	Value
A	Response type	SR: Standard Response
B	Listings and Approvals	See sections 3 and 5
C	Sprinkler type	SSU: Standard Spray Upright
D	Manufacture date (year)	See marking
E	Nominal temperature rating	See marking
F	Manufacturer's Sprinkler Identification Number (SIN)	VK1001
G	Nominal pipe engagement	7/16" (11 mm)
H	Height	1 15/16" (49 mm)

4.4 Materials of Construction

NOTICE: Do not disassemble the sprinkler.

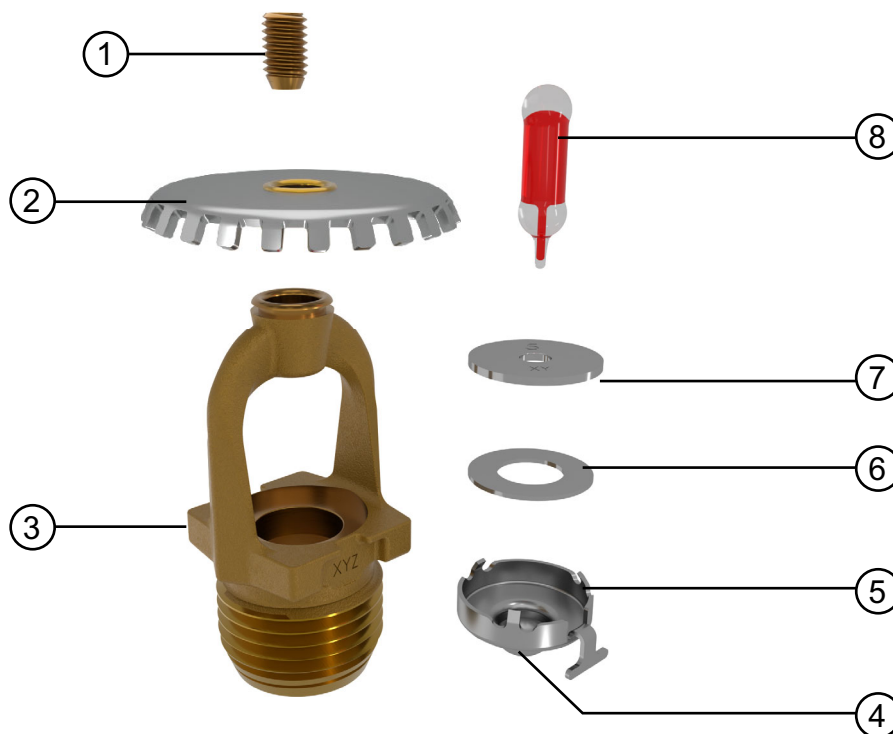

Figure – 3 Sprinkler Components

Ref	Description	Material
1	Compression screw	Brass CW612N, CW508L, UNS-C36000 or UNS-C26000
2	Deflector	Stainless steel UNS S30400
3	Sprinkler body	CW602N, UNS-C84400 or QM brass
4	Pip cap seal	Polytetrafluoroethylene (PTFE)
5	Pip cap shell	Stainless steel UNS-S44400
6	Belleville spring	Nickel alloy
7	Pip cap disc	Stainless steel UNS-S30100
8	Bulb	Glass, nominal 0.20" (5 mm) diameter

TECHNICAL DATA SHEET
**VK1001 Standard Response
Upright Sprinkler K5.6 (80.6)**
5. LISTING AND APPROVAL DESIGN REQUIREMENTS
5.1 Listing and Approval Specifications

Sprinkler Base Part Number ¹	Thread Size		Approval Body				
	NPT	BSPT	cULus		FM		
			Approval Specification	Maximum working water pressure	Approval Specification	Maximum working water pressure	
23867	1/2"	—	A1	250 psi (17 bar)	A1	175 psi (12 bar)	
23879	—	15 mm	A1	250 psi (17 bar)	A1	175 psi (12 bar)	
Additional Listings and Approvals Maximum WWP 175 psi (12 bar)							
			CE	LPCB	VdS	UKCA	MED
23867	1/2"	—	A1	A1	A1	A1	A1
23879	—	15 mm	A1	A1	A1	A1	A1
Approval Specification (Temperature Ratings) Key:							
A = 135 °F (57 °C), 155 °F (68 °C), 175 °F (79 °C), 200 °F (93 °C) and 286 °F (141 °C)							
Approval Specification (Finishes) Key:							
1 = Brass, Chrome, White Polyester ^{2,3} , Black Polyester ^{2,3} , and ENT ^{3,4}							
1 For complete part number, refer to Viking's current price list.							
2 For White Polyester and Black Polyester, other colors are available upon request and will carry the same Listings and Approvals as the standard colors.							
3 cULus Listed as corrosion resistant.							
4 FM Approved as corrosion resistant.							

5.2 cULus Listing Requirements and Details

The sprinkler is cULus Listed as indicated in Table 5.1 for installation in accordance with the latest edition of NFPA 13 for standard spray sprinklers. This sprinkler is designed for use in light, ordinary, and extra hazard occupancies.

5.3 FM Approval Requirements and Details

The sprinkler is FM Approved as standard response Non–Storage upright sprinkler as indicated in the FM Approval Guide. The sprinkler is also approved for use in FM Approved vacuum dry sprinkler systems with a maximum supervisory vacuum pressure of –3 psi (–207 mbar). FM Global Loss Prevention Data Sheets contain guidelines relating to, but not limited to: minimum water supply requirements, hydraulic design, ceiling slope and obstructions, minimum and maximum allowable spacing, and deflector distance below the ceiling. For specific application and installation requirements, refer to the latest applicable FM Loss Prevention Data Sheets (including Data Sheet 2–0).



5.4 Additional Approval Requirements and Details

Refer to Table 5.1 for approved configurations allowed by each of the following approvals.

- CE CPR: Standard EN 12259-1:1999 +A3:2006; Declaration of Performance DOP_XT1A.
- LPCB: Standard EN 12259-1:1999 +A3:2006; Certificate Number 096m.
- VdS: Standard EN 12259-1:1999 +A3:2006; Certificate Number G 422003.
- UKCA: Standard EN12259-1:1999 +A3:2006; Declaration of Conformity UKCA DOC_S5048.
- MED: Standard EN 12259-1:1999 +A3:2006; Declaration of Conformity DOC_MED_XT1.

For specific application and installation requirements, refer to the latest applicable governmental codes, ordinances, and standards for the installation location.

5.5 Corrosion Resistant Coatings

The corrosion resistant coatings have passed the standard corrosion tests required by the approving agencies and are listed and approved as indicated in Table 5.1. These tests do not represent all possible corrosive environments. The Electro-less Nickel PTFE (ENT) finish passed the UL 199 thirty day corrosion test and is cULus listed and FM Approved as corrosion resistant. For automatic sprinklers, the ENT coating is applied to all exposed exterior surfaces, including the waterway.

Prior to installation, verify that the coatings are compatible with, or suitable for, the proposed environment. The ENT finish has not been evaluated for environments containing chlorine, such as indoor swimming pools. The ENT finish is not recommended for these applications.

5.6 Sprinkler Guards and Water Shields

The sprinkler is approved for use with the Model XG Sprinkler Guard and the Model XWU upright water shield. Refer to the Guards and Water Shields for XT1 Sprinklers technical data sheet for more information.

5.7 Available Temperature Ratings

Viking sprinklers are available in several temperature ratings that relate to a specific temperature classification. Applicable installation rules mandate the use and limitations of each temperature classification. The maximum expected ceiling temperature must be known before selecting the appropriate temperature classification.

Before ordering a sprinkler, use a maximum-reading thermometer to determine the maximum expected temperature. In addition, refer to recognized installation rules which may require a higher temperature classification to be used. The rules may depend upon the following criteria:

- sprinkler location
- occupancy classification
- commodity classification
- storage height
- other nearby hazards

In all cases, the maximum expected ceiling temperature dictates the lowest allowable temperature classification. Sprinklers located immediately adjacent to a heat source may require a higher temperature rating.

TECHNICAL DATA SHEET
VK1001 Standard Response Upright Sprinkler K5.6 (80.6)
6. ORDERING PROCEDURE
6.1 Sprinkler

1. Choose a sprinkler base part number with the required thread size and listing or approval (refer to section 5):
2. Add the suffix for the desired finish.
3. Add the suffix for the desired temperature rating.

NOTE: For Polyester, insert the desired temperature rating suffix where the dash (–) is shown.

EXAMPLE: 23867MB/W = VK1001 with white polyester finish and 155 °F (68 °C) nominal temperature rating. This sprinkler is to be installed into an area with a maximum ambient temperature of 100 °F (38 °C).

1. Sprinkler Base Part Number		2. Finish		3. Temperature Rating			
See Section 5		Description	Suffix	Nominal Temperature Rating	Bulb Color	Maximum Ambient Ceiling Temperature	Suffix
23867	1/2" NPT	Brass	A	135 °F (57 °C)	Orange	100 °F (38 °C)	A
23879	15 mm BSPT	Chrome	F	155 °F (68 °C)	Red	100 °F (38 °C)	B
		White Polyester	M–/W	175 °F (79 °C)	Yellow	150 °F (65 °C)	D
		Black Polyester	M–/B	200 °F (93 °C)	Green	150 °F (65 °C)	E
		ENT	JN	286 °F (141 °C)	Blue	225 °F (107 °C)	G
				OPEN	—	—	Z

6.2 Sprinkler Accessories

Figure – 4: Sprinkler Accessories

Image Reference	Part Number	Description
1)	23559MB	Straight wrench: required for proper installation
2)	01724A	Sprinkler cabinet: holds up to 6 sprinklers
3)	01725A	Sprinkler cabinet: holds up to 12 sprinklers (not shown)

TECHNICAL DATA SHEET
**VK1001 Standard Response
Upright Sprinkler K5.6 (80.6)**
7. CONTACT

The sprinkler and accessories are available through Viking distributors only. Contact your local Viking sales office which can be found on our website:

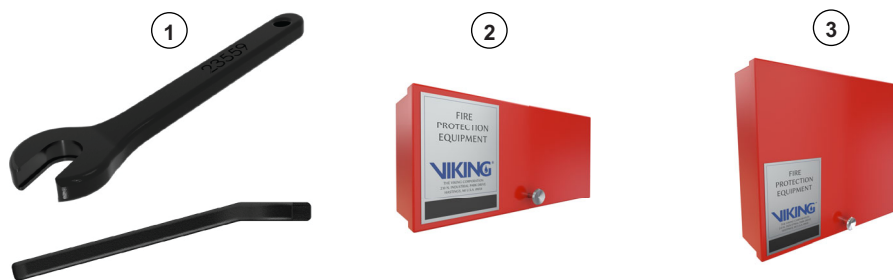
Americas and Asia: www.vikinggroupinc.com/locations OR Europe, Middle East, Africa (EMEA): www.viking-emea.com/contact

Manufacturer:

The Viking Corporation
5150 Beltway SE
Caledonia, MI 49316
Tel.: (800) 968-9501
Fax: 269-818-1680
Technical Services: 1-877-384-5464
techsvcs@vikingcorp.com

Importer EU:

Viking S.A.
21, Z.I, Haneboesch
L-4562 Differdange / Niederkorn
Tel.: +352 58 37 37 – 1
Fax: +352 58 37 36
vikinglux@viking-emea.com

Asia Pacific (APAC) Main Office:

The Viking Corporation (Far East) Pte. Ltd.
69 Tuas View Square
Westlink Techpark, Singapore 637621
Tel: (+65) 6 278 4061
Fax: (+65) 6 278 4609
vikingAPAC@vikingcorp.com



Handling and Installation Instructions

Model XT-1 Upright Sprinklers

bg	Инсталирайте и пуснете продукта в експлоатация само ако следната инструкция е ясно разбрана.	lv	Produkta iemontēšanu un ekspluatācijas sākšanu veikt tikai tad, ja dotā instrukcija ir pilnībā saprasta.
cs	Namontujte a spusťte do provozu produkt pouze tehdy, když jste jasně pochopili tento návod.	lt	Produktą montuokite ir pradėkite eksploatuoti tik tuomet, jei aiškiai suprantate šią instrukciją.
de	Du må kun montere og idriftsætte produktet, hvis du har forstået følgende vejledning til fulde.	mt	Installa u f'ad dem il-prodott biss jekk l-istruzzjonijiet li ġejjin jinftiehm u b'mod ċar.
de	Produkt nur einbauen und in Betrieb nehmen, wenn die nachfolgende Anleitung klar verstanden wird.	nl	Product alleen installeren en in gebruik nemen, als de volgende instructies begrepen zijn.
el	Η εγκατάσταση και θέση σε λειτουργία του προϊόντος επιτρέπονται μόνο εάν οι ακόλουθες οδηγίες έχουν γίνει κατανοητές.	no	Ikke installer og ta i bruk produktet uten at følgende anvisninger er tydelig forstått.
en	Do not install and commission the product unless you have clearly understood the instructions below.	pl	Produkt należy montować i uruchamiać tylko wtedy, gdy poniższe instrukcje są w pełni zrozumiałe.
es	Instalar el producto y ponerlo en funcionamiento solo cuando se hayan comprendido claramente las siguientes instrucciones.	pt	Instalar e colocar o produto em funcionamento somente se as instruções a seguir forem claramente compreendidas.
et	Paigaldage toode ja kasutage seda ainult siis, kui saate alljärgnevast juhendist selgelt aru.	ro	Montați produsul și puneți-l în funcțiune numai dacă instrucțiunea următoare este înțeleasă clar.
fi	Tuotteen saa asentaa ja ottaa käyttöön vain, jos jäljempänä oleva ohje ymmärretään selvästi.	ru	Не устанавливайте и не принимайте оборудование в эксплуатацию, если вы четко не поняли инструкции ниже
fr	N'installer et ne mettre en service le produit que si les instructions suivantes ont été clairement comprises.	sk	Namontujte a spusťte do prevádzky výrobok iba vtedy, pokiaľ ste jasne pochopili tento návod.
ga	Ná déan an táirge a shuiteail agus a choimisiunu mura dtuigeann tu na teoracha thíos go soileir.	sl	Izdelek vgradite in zaženite samo, če ste dobro razumeli navodila v nadaljevanju.
hr	Ne instalirajte i ne puštajte proizvod u rad ako niste jasno razumjeli donje upute.	sr	Не инсталирајте и не пуштајте производ у рад ако нисте јасно разумели упутства у наставку.
hu	Csak akkor építse be a terméket és helyezze üzembe, ha a következő útmutatót egyértelműen megértette.	sv	Montera och driftsätt produkten endast om du förstår den efterföljande instruktionen.
is	Settu ekki upp eða taktu vöruna í notkun nema þú hafir skilið greinilega leiðbeiningarnar hér að neðan.	tr	Aşağıdaki talimatları açıkça anlamadan ürünü kurmayın ve devreye almayın.
it	Montare il prodotto e metterlo in funzione solo se si sono comprese appieno le seguenti istruzioni.		

1. PRODUCT IDENTIFICATION

This document covers the following products, hereafter referred to as “sprinkler”:

- VK1001 Standard Response Upright Sprinkler K5.6 (80.6)
- VK2001 Standard Response Upright Sprinkler K8.0 (115)
- VK2002 Standard Response Upright Sprinkler K8.0 (115)
- VK3001 Quick Response Upright Sprinkler K5.6 (80.6)
- VK3501 Quick Response Upright Sprinkler K8.0 (115)
- VK3502 Quick Response Upright Sprinkler K8.0 (115)
- OTHER APPLICABLE DOCUMENTS

2. OTHER APPLICABLE DOCUMENTS

For intended use and relevant conditions for the safe use of the specific sprinkler refer to the appropriate *Technical Data Sheet*.



3. TRANSPORT AND HANDLING

WARNING

A damaged or compromised sprinkler poses the risk of fatal consequences.

Damaged or compromised sprinklers will not operate properly which could lead to loss of life.

- NEVER use a sprinkler that has been exposed to temperatures exceeding the maximum allowed ambient temperature.
- NEVER use a sprinkler with a loss of liquid from the glass bulb or damage to the fusible element. A small bubble should be visible within the glass bulb; rotate the sprinkler to a horizontal position while observing the bulb to see the bubble.
- NEVER use a sprinkler that has been dropped or damaged.
- ALWAYS Protect the sprinkler from mechanical damage during storage, transport, and handling.
- NEVER use sprinklers that have been painted by anyone other than the manufacturer.
- ALWAYS protect sprinklers from being painted during installation or replacement in accordance with the installation standards.
- NEVER clean sprinklers with anything other than 7 psi or lower compressed air.
- NEVER apply soap, water, ammonia, adhesives, solvents or any other fluids on sprinklers.
- Destroy every damaged or compromised sprinkler.

NOTICE

Protect sprinklers during transport and handling.

- ALWAYS handle the sprinkler with care.
- ALWAYS keep the protective cap on the sprinkler during transport and handling.
- NEVER remove the protective cap until the fire sprinkler system is placed in service and the potential for mechanical damage no longer exists.
- ALWAYS protect the sprinkler from direct sunlight during transport and handling.
- ALWAYS store sprinkler in a cool, dry, protected area.
- ALWAYS use original manufacturer's shipping containers.
- NEVER store a sprinkler loose in a box, bin, bucket, or other type of container.
- ALWAYS keep the sprinkler separated from other sprinklers.
- NEVER allow metal parts to contact the sprinkler operating elements.

NOTE: If the glass bulb included on the sprinkler has been exposed to ultraviolet light, the color inside the bulb may fade. This color change does not affect the operation of the sprinkler.

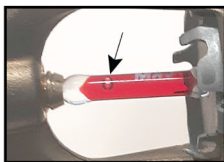

CORRECT
(Bulb intact, bubble visible)



INCORRECT
(bulb cracked, fluid missing)



CORRECT
(Protective caps in place)



INCORRECT
(Protective caps not in place)



CORRECT
Container



INCORRECT
(Stored loose in a box)



4. INSTALLATION

⚠ WARNING

Installation by insufficiently qualified personnel poses the risk of fatal consequences.

- This sprinkler must be installed properly by qualified personnel familiar with safe practices and applicable and recognized design and installation standards issued, for example, by NFPA, FM, VdS, or LPCB, and trained how to properly perform the installation procedures.

⚠ CAUTION

Cutting Hazard.

Sprinklers, accessories, cabinets, and packaging can have sharp edges that can cause cuts.

- Wear appropriate personal protective equipment (gloves) while handling product.

Optional Guards, Shields, and Escutcheons: If the sprinkler shall be installed together with a guard, shield, or escutcheon refer to the applicable documents for the products used.

1. Install all required piping in the intended installation location.
2. Verify that the sprinkler model/style, K-factor, temperature rating, and response characteristics are appropriate for the intended installation location. See Table 1 and Figure 4.
3. Inspect the sprinkler for damage. Destroy every damaged or compromised sprinkler. The following are examples in which sprinklers are considered damaged or compromised. Replace the sprinkler in the following cases:
 - Sprinkler with a loss of fluid from the glass bulb or damage to the fusible element.
 - Sprinklers that have been field painted, caulked, or mechanically damaged.
 - Sprinklers showing signs of corrosion.
4. Verify that the sprinkler is protected with the protective cap or clip.
5. Apply a small amount of pipe-joint compound or tape to the external threads of the sprinkler only. Do not allow a build-up of compound inside the sprinkler inlet (Figure 1).

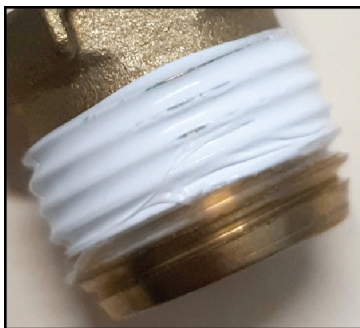

Figure – 1

6. **NOTICE: Do not use the deflector to start threading the sprinkler into a fitting. Use ONLY the approved wrench to install the sprinkler. Refer to the sprinkler’s *Technical Data Sheet*.**

Carefully slide the proper wrench onto the wrench flats (Figure 2).

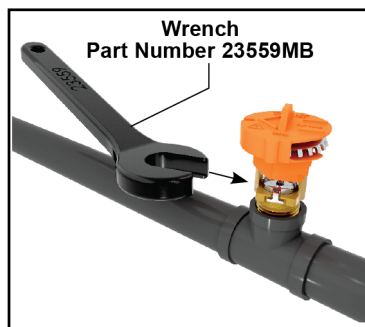

Figure – 2

7. **NOTICE: Over-tightening the sprinkler can cause permanent damage. For 1/2" NPT (or 15 mm BSPT) sprinkler, tighten up to a maximum torque of 14 ft-lbs (19 Nm). For 3/4" NPT (or 20 mm BSPT) sprinkler, tighten up to a maximum of 20 ft-lbs (27,1 Nm).**

Tighten the sprinkler as necessary (Figure 3). If applicable, install a sprinkler guard and water shield.

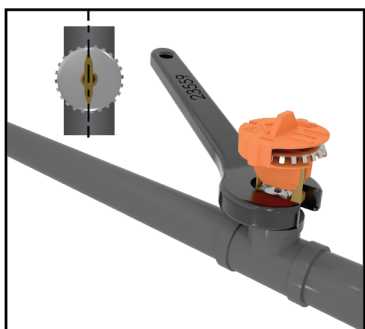

Figure – 3

8. **NOTICE: Sprinkler protective caps/clips must be removed from the sprinkler before placing the system in service. Test the entire sprinkler system.**

Refer to the applicable system documentation, regulations, and standards to ensure compliance.

Table 1: Sprinkler Markings	
Ref	Parameter
A	Response type
B	Listings and approvals
C	Sprinkler type
D	Manufacture date
E	Nominal temperature rating
F	Manufacturer’s Sprinkler Identification Number (SIN)

EXAMPLE
Figure – 4



Handling and Installation Instructions

Model XT-1 Upright Sprinklers

5. CONTACT

The sprinkler and accessories are available through Viking distributors only. Contact your local Viking sales office which can be found on our website:

Americas and Asia: www.vikinggroupinc.com/locations OR Europe, Middle East, Africa (EMEA): www.viking-emea.com/contact

Manufacturer:

The Viking Corporation
5150 Beltway SE
Caledonia, MI 49316
Tel.: (800) 968-9501
Fax: 269-818-1680
Technical Services: 1-877-384-5464
techsvcs@vikingcorp.com

Importer EU:

Viking S.A.
21, Z.I, Haneboesch
L-4562 Differdange / Niederkorn
Tel.: +352 58 37 37 – 1
Fax: +352 58 37 36
vikinglux@viking-emea.com

Asia Pacific (APAC) Main Office:

The Viking Corporation (Far East) Pte. Ltd.
69 Tuas View Square
Westlink Techpark, Singapore 637621
Tel: (+65) 6 278 4061
Fax: (+65) 6 278 4609
vikingAPAC@vikingcorp.com



1. PRODUCT IDENTIFICATION

This document covers the following product, hereafter referred to as “sprinkler” (SR=Standard Response, QR=Quick Response):

- VK1001 SR Upright Sprinkler K5.6 (80.6)
- VK2001 SR Upright Sprinkler K8.0 (115)
- VK2002 SR Upright Sprinkler K8.0 (115)
- VK3001 QR Upright Sprinkler K5.6 (80.6)
- VK3501 QR Upright Sprinkler K8.0 (115)
- VK3502 QR Upright Sprinkler K8.0 (115)
- VK1021 SR Pendent Sprinkler K5.6 (80.6)
- VK2021 SR Pendent Sprinkler K8.0 (115)
- VK2022 SR Pendent Sprinkler K8.0 (115)
- VK3021 QR Pendent Sprinkler K5.6 (80.6)
- VK3521 QR Pendent Sprinkler K8.0 (115)
- VK3522 QR Pendent Sprinkler K8.0 (115)
- VK1181 SR Conventional Sprinkler K5.6 (80.6)
- VK1201 SR Conventional Sprinkler K8.0 (115)
- VK1202 SR Conventional Sprinkler K8.0 (115)
- VK3101 QR Conventional Sprinkler K5.6 (80.6)
- VK3541 QR Conventional Sprinkler K8.0 (115)
- VK3542 QR Conventional Sprinkler K8.0 (115)

WARNING

Cancer and Reproductive Harm www.P65Warning.ca.gov

2. OTHER APPLICABLE DOCUMENTS

For intended use and relevant conditions for the safe use of the specific sprinkler, refer to the appropriate Technical Data Sheet. In case an installed sprinkler needs to be replaced, refer to the appropriate Handling and Installation Instructions for the installation of the new sprinkler.

3. MAINTAINING OPERATIONAL READINESS

Functionality

During fire conditions, the operating element fuses or shatters (depending on the type of sprinkler), releasing the pip cap and sealing assembly. Water flowing through the sprinkler orifice strikes the sprinkler deflector, forming a uniform spray pattern to control or extinguish the fire.

WARNING

This section contains important safety information. Read and follow all information.

Damaged or Compromised Sprinklers

Damaged or compromised sprinklers will not operate properly which could lead to loss of life.

- NEVER clean, paint, or caulk sprinklers.
- NEVER apply soap, water, ammonia, adhesives, solvents or any other fluids on sprinklers.
- NEVER expose sprinklers to temperatures exceeding the maximum allowed ambient ceiling temperature. See the Technical Data Sheet.
- ALWAYS replace a compromised or damaged sprinkler.
- NEVER attempt to repair or reassemble a sprinkler.
- ALWAYS replace operated sprinklers and cover assemblies and sprinklers exposed to corrosive products of combustion.
- Replacement of sprinklers must only be performed following the instructions in section 4.

The following are examples in which sprinklers are considered damaged or compromised. Replace the sprinkler in the following cases:

- Sprinkler with a loss of fluid from the glass bulb or damage to the fusible element.
- Sprinklers or cover plate assemblies that have been field painted, caulked, or mechanically damaged.
- Sprinklers showing signs of extraordinary corrosion.



Obstructions and obstacles

Obstructions and obstacles may compromise sprinkler discharge patterns which are critical for proper fire protection.

- NEVER attach items to sprinklers or hang items from the ceiling in an area protected with sprinklers.
- NEVER install walls in areas protected with sprinklers without having a specialized company verifying the design of the sprinkler system.
- ALWAYS remove obstructions and obstacles to sprinkler spray patterns.

Sprinkler systems that have been subjected to a fire

Sprinkler systems that have been subjected to a fire must be returned to service as soon as possible.

- After an event of fire, the entire sprinkler system must be inspected for damage and repaired as necessary.
- Refer to the minimum requirements of the Authority Having Jurisdiction for replacement of sprinklers.
- Consider the employment of a fire patrol as long as the sprinkler system is out of service.

Inspections and testing

The owner is responsible for having the sprinklers inspected and tested according to standards of the applicable approval body and to the requirements of the Authority Having Jurisdiction to maintain proper operating condition of the system.

- Sprinklers must be inspected on a regular basis for corrosion, mechanical damage, obstructions, paint, etc. Frequency of inspections may vary due to corrosive atmospheres, water supplies, and activity around the sprinkler.

The applicable approval body or Authority Having Jurisdiction may require sprinklers to be replaced after a specified term of service.

- Refer to the standards of the applicable approval body, such as NFPA, FM, VdS, or LPCB, and the requirements of the Authority Having Jurisdiction for detailed inspection, testing and replacements requirements.

Sprinklers removed from the system for testing or for any other purpose must be replaced according to section 4.

4. REMOVAL AND REPLACEMENT

WARNING

Removal and replacement of sprinklers by insufficiently qualified personnel poses the risk of fatal consequences in case of fire.

- Removal or replacement of sprinklers must be performed by qualified personnel familiar with safe practices and applicable and recognized design and installation standards issued, for example, by NFPA, FM, VdS, or LPCB, and trained how to properly perform the installation procedures.

WARNING

Removal and replacement of sprinklers will temporarily eliminate the fire protection capabilities of the sprinkler system.

- Consider the employment of a fire patrol in the affected area.
- Prior to proceeding, notify all Authorities Having Jurisdiction.

⚠ WARNING

Re-installation of a removed sprinkler may compromise the operational safety of the sprinkler system.

- NEVER reinstall a removed sprinkler.
 - ALWAYS use new sprinklers for replacement.
1. Select new sprinklers with identical performance characteristics as well as respective accessories such as escutcheons, cover plates, and protective caps. A stocked spare sprinkler cabinet may be provided for this purpose on site.
 2. According to appropriate system description and/or valve instructions, remove the system from service, drain all water, and relieve all pressure on the piping.
 3. Only for flush and concealed style sprinklers: Remove the ceiling ring or cover plate assembly of the old sprinkler by gently unthreading or pulling it off the sprinkler body (depends on the sprinkler model used).
 4. Use the proper sprinkler wrench for the old sprinkler according to its Technical Data Sheet.
 5. Only for flush and concealed style sprinklers, but not for domed concealed sprinklers: Replace the plastic protective cap over the old sprinkler and fit the wrench over the cap.
 6. Use the wrench to remove the old sprinkler by turning it counterclockwise to unthread it from the piping.
 7. Install the new sprinkler by following its Handling and Installation Instructions.
 8. Place the system back in service and secure all valves.
 9. Check for and repair all leaks.

5. DISPOSAL

At end of use the product described here should be disposed of via the national recycling system.

6. CONTACT

The sprinkler and accessories are available through Viking distributors only. Contact your local Viking sales office which can be found on our website:

Americas and Asia: www.vikinggroupinc.com/locations OR Europe, Middle East, Africa (EMEA): www.viking-emea.com/contact

Manufacturer:

The Viking Corporation
5150 Beltway SE
Caledonia, MI 49316
Tel.: (800) 968-9501
Fax: 269-818-1680
Technical Services: 1-877-384-5464
techsvcs@vikingcorp.com

Importer EU:

Viking S.A.
21, Z.I, Haneboesch
L-4562 Differdange / Niederkorn
Tel.: +352 58 37 37 – 1
Fax: +352 58 37 36
vikinglux@viking-emea.com

Asia Pacific (APAC) Main Office:

The Viking Corporation (Far East) Pte. Ltd.
69 Tuas View Square
Westlink Techpark, Singapore 637621
Tel: (+65) 6 278 4061
Fax: (+65) 6 278 4609
vikingAPAC@vikingcorp.com

**BULLETIN****REGULATORY AND HEALTH
WARNINGS**

The Viking Corporation, 210 N Industrial Park Drive, Hastings MI 49058

Telephone: 269-945-9501 Technical Services: 877-384-5464 Fax: 269-818-1680 Email: techsvcs@vikingcorp.com

Visit the Viking website for the latest edition of this technical data page www.vikinggroupinc.com

1. DESCRIPTION

Regulatory and Health Warnings applying to materials used in the manufacture and construction of fire protection products are provided herein as they relate to legally mandated jurisdictional regions.

⚠ WARNING**STATE OF CALIFORNIA, USA**

Installing or servicing fire protection products such as sprinklers, valves, piping etc. can expose you to chemicals including, but not limited to, lead, nickel, butadiene, titanium dioxide, chromium, carbon black, and acrylonitrile which are known to the State of California to cause cancer or birth defects or other reproductive harm.

For more information, go to www.P65Warnings.ca.gov

2. WARRANTY TERMS AND CONDITIONS

For details of warranty, refer to Viking's current list price schedule at www.vikinggroupinc.com or contact Viking directly.

CERTIFICATE OF COMPLIANCE

Certificate Number EX643
Report Reference EX643-20171207
Issue Date 2019-DECEMBER-06

Issued to: VIKING CORP
210 INDUSTRIAL PARK DR
HASTINGS MI 49058-9706

This certificate confirms that representative samples of SPRINKLERS, AUTOMATIC AND OPEN
SEE ADDENDUM PAGE FOR MODELS

Have been investigated by UL in accordance with the Standard(s) indicated on this Certificate.

Standard(s) for Safety: UL199 standard for Standard for Automatic Sprinklers for Fire-Protection Service
ULC/ORD-C199-03 standard for ULC Other Recognized Document for Automatic Sprinklers Fire Protection Service
UL 199D and ULC/ORD- C199D-03 standard for Outline of Investigation for Guards for Sprinklers

Additional Information: See the UL Online Certifications Directory at <https://iq.ulprospector.com> for additional information.

This *Certificate of Compliance* does not provide authorization to apply the UL Mark. Only the UL Follow-Up Services Procedure provides authorization to apply the UL Mark.

Only those products bearing the UL Mark should be considered as being UL Certified and covered under UL's Follow-Up Services.

Look for the UL Certification Mark on the product.

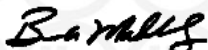

Bruce Mahrenholz, Director North American Certification Program

UL LLC

Any information and documentation involving UL Mark services are provided on behalf of UL LLC (UL) or any authorized licensee of UL. For questions, please contact a local UL Customer Service Representative at <http://ul.com/aboutul/locations/>



CERTIFICATE OF COMPLIANCE

Certificate Number EX643
Report Reference EX643-20171207
Issue Date 2019-DECEMBER-06

This is to certify that representative samples of the product as specified on this certificate were tested according to the current UL requirements.

Models/Product

Automatic sprinklers incorporating a glass bulb of the following models, types and temperature ratings:

Listing s	SIN	Response Type	Sprinkler Type	Nominal K-Factor	System Working Pressure, psig	Temperature Rating, °F
USL, CNL	VK100 1	SR	Upright	5.6	250	135, 155, 175, 200, 286, 360
USL, CNL	VK100 1	SR	Intermediate Level Upright	5.6	250	135, 155, 175, 200, 286, 360
USL, CNL	VK102 1	SR	Pendent	5.6	250	135, 155, 175, 200, 286, 360
USL, CNL	VK102 1	SR	Intermediate Level Pendent	5.6	250	135, 155, 175, 200, 286, 360
USL, CNL	VK118 1	SR	Conventional	5.6	175	135, 155, 175, 200, 286, 360
USL, CNL	VK120 1	SR	Conventional	8.0	175	135, 155, 175, 200, 286, 360
USL, CNL	VK200 1	SR	Intermediate Level Upright	8.0	175	135, 155, 175, 200, 286, 360
USL, CNL	VK120 2	SR	Conventional, ½ NPT	8.0	175	135, 155, 175, 200, 286, 360
USL, CNL	VK200 1	SR	Upright	8.0	175	135, 155, 175, 200, 286, 360
USL, CNL	VK200 2	SR	Upright, ½ NPT	8.0	175	135, 155, 175, 200, 286, 360
USL, CNL	VK200 2	SR	Intermediate Level Upright, ½ NPT	8.0	175	135, 155, 175, 200, 286, 360
USL, CNL	VK202 1	SR	Pendent	8.0	175	135, 155, 175, 200, 286, 360
USL, CNL	VK202 1	SR	Intermediate Level Pendent	8.0	175	135, 155, 175, 200, 286, 360
USL, CNL	VK202 2	SR	Pendent, ½ NPT	8.0	175	135, 155, 175, 200, 286, 360
USL, CNL	VK202 2	SR	Intermediate Level Pendent, ½ NPT	8.0	175	135, 155, 175, 200, 286, 360
USL, CNL	VK300 1	QR	Upright	5.6	250	135, 155, 175, 200, 286
USL, CNL	VK300 1	QR	Intermediate Level Upright	5.6	250	135, 155, 175, 200, 286



Bruce Mahrenholz, Director North American Certification Program

UL LLC

Any information and documentation involving UL Mark services are provided on behalf of UL LLC (UL) or any authorized licensee of UL. For questions, please contact a local UL Customer Service Representative at <http://ul.com/aboutul/locations/>



CERTIFICATE OF COMPLIANCE

Certificate Number EX643
Report Reference EX643-20171207
Issue Date 2019-DECEMBER-06

USL, CNL	VK302 1	QR	Pendent	5.6	250	135,155,175,2 00,286
USL, CNL	VK302 1	QR	Intermediate Level Pendent	5.6	250	135,155,175,2 00,286
USL, CNL	VK310 1	QR	Conventional	5.6	175	135,155,175,2 00,286
USL, CNL	VK350 1	QR	Upright	8.0	175	135,155,175,2 00,286
USL, CNL	VK350 1	QR	Intermediate Level Upright	8.0	175	135,155,175,2 00,286
USL, CNL	VK350 2	QR	Upright, ½ NPT	8.0	175	135,155,175,2 00,286
USL, CNL	VK350 2	QR	Intermediate Level Upright, ½ NPT	8.0	175	135,155,175,2 00,286
USL, CNL	VK352 1	QR	Pendent	8.0	175	135,155,175,2 00,286
USL, CNL	VK352 1	QR	Intermediate Level Pendent	8.0	175	135,155,175,2 00,286
USL, CNL	VK352 2	QR	Pendent, ½ NPT	8.0	175	135,155,175,2 00,286
USL, CNL	VK352 2	QR	Intermediate Level Pendent, ½ NPT	8.0	175	135,155,175,2 00,286
USL, CNL	VK354 1	QR	Conventional	8.0	175	135,155,175,2 00,286
USL, CNL	VK354 2	QR	Conventional, ½ NPT	8.0	175	135,155,175,2 00,286



Bruce Mahrenholz, Director North American Certification Program

UL LLC

Any information and documentation involving UL Mark services are provided on behalf of UL LLC (UL) or any authorized licensee of UL. For questions, please contact a local UL Customer Service Representative at <http://ul.com/aboutul/locations/>



Non-Storage / Special Protection / Storage Sprinklers General Information

Automatic sprinkler protection is recommended for industrial and other buildings having combustible construction or combustible occupancies.

When selecting a specific type of sprinkler, refer to the FM Global Property Loss Prevention Data Sheets to ensure that the sprinkler selected is capable of providing adequate fire protection for the intended occupancy. Projects that are specific to FM Global insured clients, working plans of proposed layouts, showing all details with respect to location of sprinklers and piping, description of the occupancy and details of construction, should be sent to the local FM Global engineering office for review and acceptance before the materials are fabricated. The plans will be accepted or changes will be recommended to assure that the work will be done according to the best practice and to avoid the possibility of later requests for changes.

Nominal thread sizes are expressed using American National Standard Taper Pipe Threads (NPT). Sprinklers intended for sale outside the United States shall have threads which are in compliance with other national or international standards as permitted at the sole discretion of FM Approvals.

Unless otherwise noted, automatic sprinklers have a rated working pressure of 175 psi (12.1 bar).

Sprinkler Categories

There are three categories of FM Approved automatic sprinklers: Storage, Non-Storage and Special Protection sprinklers based on the type of occupancy hazard they are intended to protect. Within these three categories are various different types of orientations (such as pendent, upright, horizontal sidewall, vertical sidewall, flush, recessed, concealed, dry pendent, dry upright, etc.), thermal response ratings (i.e. quick response or standard response), nominal temperature ratings (see table below), K-factors (see table below) and spacings (i.e. standard or extended coverage).

Nominal K-Factors of Sprinklers

The sprinkler nominal discharge coefficient (K-factor) is expressed in US customary units of gal/min/(psi)^{0.5}. See the table below for nominal K-factor values of currently Approved sprinklers.

Nominal K-Factors of Approved Sprinklers

Nominal K-Factor, gpm/(psi)^{1/2}	Metric K-Factor, lpm/(bar)^{1/2}
2.8	40
5.6	80
8.0	115
11.2	160
14.0	200
16.8	240
19.6	280
22.4	320
25.2	360

The following table provides the nominal K-factor values of currently Approved Special Protection (Residential) sprinklers.

Nominal K-Factors of Approved Special Protection (Residential) Sprinklers

Nominal K-Factor, gpm/(psi)^{1/2}	Metric K-Factor, lpm/(bar)^{1/2}
3.8	55
5.8	85
6.9	100

Nominal Temperature Rating of Sprinklers

A sprinkler operates automatically when the heat-actuated element is heated to, or above, its thermal rating. Selection of the proper temperature rating for automatic sprinklers is important as it provides a factor of safety designed to prevent premature operation. See the table below as well as the occupancy-specific FM Global data sheet to ensure the proper nominal temperature rating for the sprinkler is chosen based on the hazard being protected as well as the expected ambient temperature conditions. Factory coated, plated and painted sprinklers rated above 165°F (74°C) have the standard temperature color code either on the frame arms or on the compression screws, except in the case of bulb type decorative coated sprinklers in which the bulb fluid color indicates the temperature rating per the following table:

Nominal Temperature Ratings of Sprinklers Based on Maximum Ambient Temperature at Sprinkler Level

Nominal Temperature Rating of Sprinkler*	Maximum Ambient Temperature at Sprinkler Level	Temperature Range of Nominal Rating**	Temperature Classification of Sprinkler	Color of Sprinkler Frame	Color and Temperature of Sprinkler Glass Bulb
135°F (55°C)	100°F (38°C)	135°F (57°C)	Ordinary	Unpainted	Orange, 135°F (57°C)
160°F (70°C)	100°F (38°C)	155°F - 165°F (68°C - 74°C)	Ordinary	Unpainted	Red, 155°F (68°C)
175°F (80°C)	150°F (66°C)	175°F (79°C)	Intermediate	White	Yellow, 175°F (79°C)
212°F (100°C)	150°F (66°C)	200°F - 220°F (93°C - 104°C)	Intermediate	White	Green, 200°F & 225°F (93°C & 107°C)
280°F (140°C)	225°F (107°C)	280°F - 286°F (138°C - 141°C)	High	Blue	Blue, 250°F & 286°F (121°C & 141°C)
350°F (175°C)	300°F (149°C)	325°F - 375°F (163°C - 191°C)	Extra High	Red	Mauve, 325°F & 360°F (162°C & 182°C)
425°F (220°C)	375°F (191°C)	400°F - 475°F (204°C - 246°C)	Very Extra High	Green	Black, 400°F - 650°F (204°C - 343°C)
525°F (275°C)	475°F (246°C)	500°F - 575°F (260°C - 302°C)	Ultra High	Orange	Black, 400°F - 650°F (204°C - 343°C)
650°F (345°C)	625°F (329°C)	650°F (343°C)	Ultra High	Orange	Black, 400°F - 650°F (204°C - 343°C)

*The values indicated for nominal temperature ratings of sprinkler in this table are based on values indicated in FM Global data sheets

**The values indicated are based on the actual (marked or marked nominal) temperature ratings of currently Approved sprinklers

Sprinklers of "very extra high" and "ultra high" ratings are primarily used for internal protection of chambers such as ovens and dryers having working temperatures above 300°F (149°C). When the sprinklers are normally heated to the working temperature of the oven or dryer, under fire conditions they will operate fast enough for proper protection. However, when the sprinklers are initially at the same temperature as a cold oven or dryer, operation may be so severely retarded that the oven or dryer is virtually without internal sprinkler protection.

Nominal Response Rating of Sprinklers

Approved sprinklers are listed in one of three ways for response ratings: fast response (FR), quick response (QR) or standard response (SR) and are reflective of the response of the entire sprinkler to thermal exposure, not just the thermal sensing element of the sprinkler. Note that fast response (FR) sprinklers are a subset of quick response sprinklers for listing purposes.

The thermal sensing elements of the sprinkler are identified as either Fusible or, in the case of bulb type elements, nominal bulb

diameter in millimeters (e.g., 2.5 mm, 3 mm, etc.).

Finishes and Coatings of Sprinklers

Approved sprinklers are also available with factory-applied special coatings for resistance to corrosive environments; such sprinklers are listed under the Special Protection sprinkler category. For corrosion resistance, wax is satisfactory except in extreme atmospheres. Wax has too low a melting point for high temperature rated sprinklers, whereas a bituminous coating affords some protection. A lead coating protects against certain mild corrosive atmospheres. Wax-over-lead provides good sprinkler protection. Corrosion resistant sprinklers such as those manufactured from stainless steel or other corrosion resistant materials currently afford the best available protection. See the FM Global occupancy-specific data sheet to determine when a corrosion resistant sprinkler is needed and, if so, which type offers the best resistance for the environmental conditions.

FM Approved sprinklers are available with common decorative finishes such as factory-applied bright brass, chrome, paint, or polyester coating. Note that these finishes are for decorative purposes only and are not FM Approved specifically for corrosive environments.

Finishes of currently Approved Storage and Non-Storage sprinklers are included in the following table.

Factory-Applied Finishes of Approved Storage and Non-Storage Sprinklers

<i>Finish</i>	<i>Description</i>
<i>Black Plated</i>	<i>Black Plated</i>
<i>Brass</i>	<i>Unfinished, Plain Brass or Bronze</i>
<i>Bright Brass</i>	<i>Bright Brass Plated</i>
<i>Chrome</i>	<i>Chrome Plated</i>
<i>Painted</i>	<i>Painted (any color)</i>
<i>Polyester</i>	<i>Polyester Coated (any color)</i>
<i>Zinc</i>	<i>Zinc Plated</i>

Finishes of currently Approved Special Protection (Corrosive Environment) sprinklers are included in the following table. Note that FM Approved Special Protection (Corrosive Environment) sprinklers are also acceptable for use as Non-Storage sprinklers, unless indicated otherwise by the occupancy-specific FM Global data sheet.

Finishes of Approved Special Protection (Corrosive Environment) Sprinklers

Finish	Description
<i>Lead</i>	<i>Lead Coated (for extra corrosion protection in some atmospheres)</i>
<i>NICOTEF</i>	<i>Nickel-Teflon Coating (for extra corrosion protection in some atmospheres)</i>
<i>Stainless Steel</i>	<i>Stainless Steel Alloy (for extra corrosion protection in some atmospheres)</i>
<i>Wax</i>	<i>Wax Coated (for extra corrosion protection in some atmospheres)</i>
<i>Wax Over Brass</i>	<i>Wax Over Brass Coated (for extra corrosion protection in some atmospheres)</i>
<i>Wax Over Lead</i>	<i>Wax Over Lead Coated (for extra corrosion protection in some atmospheres)</i>
<i>Wax Over Polyester</i>	<i>Wax Over Polyester Coated (for extra corrosion protection in some atmospheres)</i>

Only sprinklers supplied by the listed manufacturers are FM Approved. Any change in the device after it leaves the manufacturer voids the Approval.

Note that Approved Special Protection (Corrosive Environment) sprinklers can also be installed in applications acceptable for both Approved Non-Storage and Storage sprinklers having the same K-factor, orientation, RTI, nominal temperature rating and sprinkler spacing.

Non-Storage Sprinklers and Storage Sprinklers

Orientation

Adjustable Concealed Pendent

Adjustable concealed pendent sprinklers incorporate a cover plate which is heat activated and can be manually removed to prevent over-painting of the cover plate. They are intended for use with concealed sprinkler piping where attractive appearance under a ceiling is desired; such occupancies may include offices, hotel lobbies, dining rooms, clubs and similar properties. FM Approved adjustable concealed pendent sprinklers are limited to a maximum temperature rating of 225°F (107°C) and to protection of hazard occupancies as outlined in the occupancy-specific FM Global Property Loss Prevention Data Sheet. They should not be installed in corrosive environments. Unless indicated otherwise by the occupancy-specific FM Global Property Loss Prevention Data Sheet, these sprinklers are FM Approved only for use in wet systems as well as pre-action systems that qualify as a wet system.

Dry Adjustable Horizontal Sidewall

A dry-type sprinkler consists of a sprinkler permanently attached to an extension nipple which has a closure at the inlet end to prevent system water from entering the nipple until the sprinkler operates.

Adjustable dry horizontal sidewall sprinklers are dry-type sprinklers in which the sprinklers attached to the nipple extension are of the horizontal sidewall orientation. They are intended for installation near a wall/ceiling interface and are equipped with a special deflector which discharges most of the water in a horizontal plane so that the water is directed onto adjacent walls as well as the protected area. These types of sprinklers are typically used to protect areas subject to freezing and are connected to water-filled sprinkler piping located adjacent to the protected area in a location not susceptible to freezing. They are also sometimes used on dry type sprinkler systems where the installed sprinkler must be of the sidewall orientation. The sprinklers are generally intended for locations such as offices, hotel lobbies and dining rooms, where the installation of Non-Storage pendent or upright sprinklers with the usual ceiling spacing and pipe location may be objectionable because of appearance. They are also installed for special circumstances where their directional properties are desirable.

Dry Adjustable Pendent

A dry-type sprinkler consists of a sprinkler permanently attached to an extension nipple which has a closure at the inlet end to prevent system water from entering the nipple until the sprinkler operates.

Adjustable dry pendent sprinklers are dry-type sprinklers in which the sprinkler attached to the nipple extension is of the pendent orientation. These types of sprinklers are typically used to protect areas subject to freezing and are connected to water-filled sprinkler piping located above the protected area in a location not susceptible to freezing. They are also sometimes used on dry type sprinkler systems where the installed sprinkler must be of the pendent orientation.

Adjustable Recessed Pendent

Adjustable recessed pendent sprinklers consist of a pendent sprinkler installed in a decorative recessed cup which reduces the protrusion of the sprinkler from the ceiling. They are intended for use with concealed sprinkler piping where attractive appearance under a ceiling is desired; such occupancies may include offices, hotel lobbies, dining rooms, clubs and similar properties. FM Approved adjustable recessed pendent sprinklers are limited to a maximum temperature rating of 225°F (107°C) and to protection of hazard occupancies as outlined in the occupancy-specific FM Global Property Loss Prevention Data Sheet. Unless indicated otherwise by the occupancy-specific FM Global Property Loss Prevention Data Sheet, these sprinklers are FM Approved only for use in wet systems as well as pre-action systems that qualify as a wet system.

Concealed Pendent

Concealed pendent sprinklers incorporate a cover plate which is heat activated and can be manually removed to prevent over-painting of the cover plate. They are intended for use with concealed sprinkler piping where attractive appearance under a ceiling is desired; such occupancies may include offices, hotel lobbies, dining rooms, clubs and similar properties. FM Approved concealed pendent sprinklers are limited to a maximum temperature rating of 225°F (107°C) and to protection of hazard occupancies as outlined in the occupancy-specific FM Global Property Loss Prevention Data Sheet. They should not be installed in corrosive environments. Unless indicated otherwise by the occupancy-specific FM Global Property Loss Prevention Data Sheet, these sprinklers are FM Approved only for use in wet systems as well as pre-action systems that qualify as a wet system.

Dry Concealed Pendent

A dry-type sprinkler consists of a sprinkler permanently attached to an extension nipple which has a closure at the inlet end to prevent system water from entering the nipple until the sprinkler operates.

Dry concealed pendent sprinklers are dry-type sprinklers in which the sprinklers attached to the nipple extension are of the pendent orientation. Dry concealed pendent sprinklers incorporate a cover plate which is heat activated and can be manually removed to prevent over-painting of the cover plate. These types of sprinklers are typically used to protect areas subject to freezing and are connected to water-filled sprinkler piping located adjacent to the protected area in a location not susceptible to freezing. They are also sometimes used on dry type sprinkler systems where the installed sprinkler must be of the pendent orientation. The sprinklers are generally intended for use with concealed sprinkler piping where attractive appearance under a ceiling is desired; such occupancies

may include offices, hotel lobbies, dining rooms, clubs and similar properties. They should not be installed in corrosive environments. FM Approved dry concealed pendent sprinklers are limited to a maximum temperature rating of 225°F (107°C) and to protection of hazard occupancies as outlined in the occupancy-specific FM Global Property Loss Prevention Data Sheet.

Dry Horizontal Sidewall

A dry-type sprinkler consists of a sprinkler permanently attached to an extension nipple which has a closure at the inlet end to prevent system water from entering the nipple until the sprinkler operates.

Dry horizontal sidewall sprinklers are dry-type sprinklers in which the sprinklers attached to the nipple extension are of the horizontal sidewall orientation. They are intended for installation near a wall/ceiling interface and are equipped with a special deflector which discharges most of the water in a horizontal plane so that the water is directed onto adjacent walls as well as the protected area. These types of sprinklers are typically used to protect areas subject to freezing and are connected to water-filled sprinkler piping located adjacent to the protected area in a location not susceptible to freezing. They are also sometimes used on dry type sprinkler systems where the installed sprinkler must be of the sidewall orientation. The sprinklers are generally intended for locations such as offices, hotel lobbies and dining rooms, where the installation of Non-Storage pendent or upright sprinklers with the usual ceiling spacing and pipe location may be objectionable because of appearance. They are also installed for special circumstances where their directional properties are desirable.

Dry Pendent

A dry-type sprinkler consists of a sprinkler permanently attached to an extension nipple which has a closure at the inlet end to prevent system water from entering the nipple until the sprinkler operates.

Dry pendent sprinklers are dry-type sprinklers in which the sprinkler attached to the nipple extension is of the pendent orientation. These types of sprinklers are typically used to protect areas subject to freezing and are connected to water-filled sprinkler piping located above the protected area in a location not susceptible to freezing. They are also sometimes used on dry type sprinkler systems where the installed sprinkler must be of the pendent orientation.

Dry Recessed Horizontal Sidewall

A dry-type sprinkler consists of a sprinkler permanently attached to an extension nipple which has a closure at the inlet end to prevent system water from entering the nipple until the sprinkler operates.

Dry recessed horizontal sidewall sprinklers are dry-type sprinklers in which the sprinklers attached to the nipple extension are of the horizontal sidewall orientation and are installed in a decorative recessed cup which reduces the protrusion of the sprinkler from the wall. These types of sprinklers are typically used to protect areas subject to freezing and are connected to water-filled sprinkler piping located adjacent to the protected area in a location not susceptible to freezing. They are also sometimes used on dry type sprinkler systems where the installed sprinkler must be of the sidewall orientation.

Dry Recessed Pendent

A dry-type sprinkler consists of a sprinkler permanently attached to an extension nipple which has a closure at the inlet end to prevent system water from entering the nipple until the sprinkler operates.

Dry recessed pendent sprinklers are dry-type sprinklers in which the sprinklers attached to the nipple extension are of the pendent orientation and are installed in a decorative recessed cup which reduces the protrusion of the sprinkler from the ceiling. These types of sprinklers are typically used to protect areas subject to freezing and are connected to water-filled sprinkler piping located above the protected area in a location not susceptible to freezing. They are also sometimes used on dry type sprinkler systems where the installed sprinkler must be of the pendent orientation.

Dry Upright

A dry-type sprinkler consists of a sprinkler permanently attached to an extension nipple which has a closure at the inlet end to prevent system water from entering the nipple until the sprinkler operates.

Dry upright sprinklers are dry-type sprinklers in which the sprinklers attached to the nipple extension are of the upright orientation. These types of sprinklers are typically used to protect areas subject to freezing and are connected to water-filled sprinkler piping located below the protected area in a location not susceptible to freezing.

Flush Pendent

Flush pendent sprinklers are constructed with an operating element which extends a short distance below the ceiling. Upon actuation, the sprinkler deflector drops below the ceiling level to provide a proper water distribution. They are intended for use with concealed sprinkler piping where attractive appearance under a ceiling is desired; such occupancies may include offices, hotel lobbies, dining rooms, clubs and similar properties. They should not be installed in corrosive environments. FM Approved flush pendent sprinklers are limited to a maximum temperature rating of 225°F (107°C) and to protection of hazard occupancies as outlined in the occupancy-specific FM Global Property Loss Prevention Data Sheet. Unless indicated otherwise by the occupancy-specific FM Global Property Loss Prevention Data Sheet, these sprinklers are FM Approved only for use in wet systems as well as pre-action systems that qualify as a wet system.

Horizontal Sidewall

Sidewall sprinklers are sprinklers that are intended for installation near a wall/ceiling interface. They are equipped with a special deflector which discharges most of the water in a horizontal plane so that the water is directed onto adjacent walls as well as the protected area. The sprinklers are generally intended for locations such as offices, hotel lobbies and dining rooms, where the installation of Non-Storage pendent or upright sprinklers with the usual ceiling spacing and pipe location may be objectionable because of appearance. They are also installed for special circumstances where their directional properties are desirable.

Horizontal sidewall automatic sprinklers are sidewall-type sprinklers in which the axis of the sprinkler orifice is oriented horizontally.

Pendent

Pendent automatic sprinklers are sprinklers designed such that the water discharge from the sprinkler orifice is directed downward towards the deflector which in turn directs the water downward toward the protected area. The sprinkler is designed such that the deflector is located below the pipe to which the sprinkler is connected.

Recessed Horizontal Sidewall

Sidewall sprinklers are sprinklers that are intended for installation near a wall/ceiling interface. They are equipped with a special deflector which discharges most of the water in a horizontal plane so that the water is directed onto adjacent walls as well as the protected area. The sprinklers are generally intended for locations such as offices, hotel lobbies and dining rooms, where the installation of Non-Storage pendent or upright sprinklers with the usual ceiling spacing and pipe location may be objectionable because of appearance. They are also installed for special circumstances where their directional properties are desirable.

Recessed horizontal sidewall sprinklers consist of a horizontal sidewall sprinkler installed in a decorative recessed cup which reduces the protrusion of the sprinkler from the wall. They are intended for use with concealed sprinkler piping where attractive appearance is desired; such occupancies may include offices, hotel lobbies, dining rooms, clubs and similar properties.

Recessed Pendent

Recessed pendent sprinklers consist of a pendent sprinkler installed in a decorative recessed cup which reduces the protrusion of the sprinkler from the ceiling. They are intended for use with concealed sprinkler piping where attractive appearance under a ceiling is desired; such occupancies may include offices, hotel lobbies, dining rooms, clubs and similar properties. FM Approved recessed pendent sprinklers are limited to a maximum temperature rating of 225°F (107°C) and to protection of hazard occupancies as outlined in the occupancy-specific FM Global Property Loss Prevention Data Sheet. Unless indicated otherwise by the occupancy-specific FM Global Property Loss Prevention Data Sheet, these sprinklers are FM Approved only for use in wet systems as well as pre-action systems that qualify as a wet system.

Upright

Upright automatic sprinklers are sprinklers designed such that the water discharge from the sprinkler orifice is directed upward towards the deflector which in turn redirects the water downward toward the protected area. The sprinkler is designed such that the deflector is located above the pipe to which the sprinkler is connected.

Vertical Sidewall

Sidewall sprinklers are sprinklers that are intended for installation near a wall/ceiling interface. They are equipped with a special deflector which discharges most of the water in a horizontal plane so that the water is directed onto adjacent walls as well as the protected area. The sprinklers are generally intended for locations such as office, hotel lobbies, and dining rooms, where the installation of Non-Storage pendent or upright sprinklers with the usual ceiling spacing and pipe location may be objectionable because of appearance. They are also installed for special circumstances where their directional properties are desirable.

Vertical sidewall automatic sprinklers are sidewall-type sprinklers in which the axis of the sprinkler orifice is oriented vertically. They are FM Approved for use in both the upright and pendent positions, except where noted otherwise.

Non-Storage Sprinklers

A Non-Storage automatic sprinkler is a sprinkler that has been categorized by FM Global as acceptable for protecting non-storage-type occupancies and/or other occupancy hazards characterized by low to moderate heat-release rate fires as permitted in a FM Global occupancy-specific Property Loss Prevention Data Sheet.

K5.6 (K80 metric)

Non-Storage automatic sprinklers having a K-factor value of 5.6 (80 metric) are similar to Non-Storage automatic sprinklers having a K-factor value of 2.8 (40 metric), except that they discharge 100% more water at the same discharge pressure and typically do not require the use of individual or system strainers. Pendent sprinklers of this K-factor would, however, require the installation of a return bend if the water supply is fed from an open-body type source. See FM Global Property Loss Prevention Data Sheet 2-0, *Installation Guidelines for Automatic Sprinklers*, for additional details and requirements regarding these sprinklers.

K5.6 (K80 metric) Upright

VK1001

Company Name:	The Viking Corporation
Company Address:	5150 Beltway Dr SE, Caledonia, Michigan 49316, USA
Company Website:	http://vikingcorp.com
New/Updated Product Listing:	No
Class of Work:	2016-AS, Control Mode, Upright

Listing Country:	United States of America
Sprinkler Category:	Non Storage
K:	5.6
Type:	Upright
Response:	SR - Standard Response
Element:	5 mm
NPT (in.):	1/2
Finish:	Brass, Chrome, Electroless Nickel PTFE (ENT), Polyester
Temp. Rating (°F):	135, 155, 175, 200, 286
Temp. Rating (°C):	57, 68, 79, 93, 141
Certification Type:	FM Approved