

ALARM CHECK VALVE

BRAND	:	VIKING
MANUFACTURER	:	VIKING CORPORATION
COUNTRY	:	USA.
MODEL	:	J-1
TYPE	:	VERTICAL TRIM
	:	HORIZONTAL TRIM
ACCESSORIES	:	TRIM, RETARD & GONG
APPROVED	:	UL/FM
SIZE	:	3", 4" , 6" , 8"
CONNECTION	:	FLANGED ENDS
MAX. WORKING PRESSURE	:	300 PSI.

MATERIAL LIST

BODY	:	DUCTILE IRON
CLAPPER	:	TEFLON
CLAPPER FACING	:	EPDM
SPRING	:	STAINLESS STEEL

	<h1 style="margin: 0;">TECHNICAL DATA</h1>	<div style="background-color: yellow; padding: 5px; display: inline-block;"> ALARM CHECK VALVE MODEL J-1 </div>
---	--	--

The Viking Corporation, 210 N Industrial Park Drive, Hastings MI 49058

Telephone: 269-945-9501 Technical Services: 877-384-5464 Fax: 269-818-1680 Email: techsvcs@vikingcorp.com

1. DESCRIPTION

The Viking Model J-1 Alarm Check Valve serves as a check valve by trapping pressurized water above the clapper and preventing reverse flow from sprinkler piping.

The valve is designed to initiate an alarm during a sustained flow of water (such as the flow required by an open sprinkler) by operating an optional water motor alarm and/or alarm pressure switch. The valve is made suitable for use on variable pressure water supplies by adding the optional retard chamber to the standard trim.

Features

- Ductile iron body for less weight and extra strength.
- Rubber-faced clapper hinged to access cover for quick removal and easy servicing.
- All moving parts can be serviced without removing the valve from the installed position.
- With the cover/clapper assembly removed, clapper rubber replacement requires removal of only one screw.
- External by-pass trim to minimize clapper movement and false alarm.
- Trim allows installation of optional non-interruptible pressure switch to activate an electric alarm panel and/or remote alarm.
- Can be installed on constant or variable pressure water supplies.
- Can be installed vertically or horizontally, with the access cover facing up.
- Valve housing tapped for inlet and outlet pressure gauges, alarm devices, and system main drain.
- Trim includes alarm test valve for testing alarms without reducing system pressure.



2. LISTINGS AND APPROVALS



cULus Listed: Guide VPLX - 300 psi (20.7 bar) MWP



FM Approved: Waterflow Alarm Valves - 300 psi (20.7 bar) MWP

American Bureau of Shipping (ABS): Certificate No. 03-HS405911A/1-PDA

NYC Department of Buildings: MEA 89-92-E Vol. XI - 250 psi (17.2 bar) MWP



LPCB: 300 psi (20.7 bar) MWP



VdS: DN80 - G 4960086, DN100 - G 4960087, DN150 - G 4960088, DN200 - G 4960089 - 250 psi (17.2 bar) MWP



CE Certified: Standard EN-12259-2, EC-certificate of conformity 0832-CPD-2010 - 250 psi (17.2 bar) MWP

Viking Technical Data may be found on The Viking Corporation's Web site at <http://www.vikinggroupinc.com>. The Web site may include a more recent edition of this Technical Data Page.

3. TECHNICAL DATA

Specifications

Friction Loss - Refer to Table 1

Pressure Rating - 300 psi (20.7 bar) water working pressure.

Factory tested hydrostatically to 600 psi (41.4 bar).

The valve may be hydrostatically tested at 350 psi (24.1 bar) and/or 50 psi (3.4 bar) above the normal water working pressure, for limited periods of time (two hours), for the purpose of acceptance by the AHJ. If air testing is required, DO NOT exceed 40 psi (2.8 bar) air pressure.

$$Q = C_v \sqrt{\frac{\Delta P}{S}}$$

Q = Flow
 C_v = Flow Factor (GPM/1 PSI ΔP)
 ΔP = Pressure Loss through Valve
 S = Specific Gravity of Fluid

Material Standards

Refer to Table 1.

Ordering Information

The valve is listed and/or approved with specific trim for use up to 300 psi (20.7 bar). No substitutions or omissions, in part or in full, are allowed. Additional accessories to the standard trim packages are required for a complete system meeting the requirements of the applicable rules and codes. See appropriate technical data for additional information.

Part Numbers - Refer to Table 1.

Accessories -

- a. Retard Chamber: Required when the Model J-1 Alarm Check Valve is installed on systems with a variable pressure water supply to minimize unwanted (false) alarms.
- b. Water Motor Alarm: The J-1 Alarm Check Valve is designed to operate a mechanical alarm during a sustained flow of water (such as the flow required by an open sprinkler). Refer to the water motor alarm technical data.



TECHNICAL DATA

ALARM CHECK VALVE MODEL J-1

The Viking Corporation, 210 N Industrial Park Drive, Hastings MI 49058

Telephone: 269-945-9501 Technical Services: 877-384-5464 Fax: 269-818-1680 Email: techsvcs@vikingcorp.com

Table 1 - Specifications

	Nominal Size	Part Number	Friction Loss*	Shipping Weight
Flange/Flange				
Flange Drilling	Model J-1			
ANSI	3"	08235	10 ft. (3.1 m)	35 lbs. (16 kg)
ANSI	4"	08238	13 ft. (4.0 m)	47 lbs. (21 kg)
ANSI	6"	08241	20 ft. (6.0 m)	75 lbs. (34 kg)
ANSI	8"	08244	23 ft. (7.0 m)	135 lbs. (61 kg)
PN10/16	DN80	09108	10 ft. (3.1 m)	35 lbs. (16 kg)
PN10/16	DN100	09109	13 ft. (4.0 m)	47 lbs. (21 kg)
PN10/16	DN150	09110	20 ft. (6.0 m)	75 lbs. (34 kg)
PN10	DN200	09111	23 ft. (7.0 m)	135 lbs. (61 kg)
PN16	DN200	12388	23 ft. (7.0 m)	135 lbs. (61 kg)

* Expressed in equivalent length of Schedule 40 pipe based on Hazen & Williams formula C = 120.

	Nominal Size	Part Number	Friction Loss*	Shipping Weight
Flange/Groove				
Flange Drilling / Pipe O.D.	Model J-1			
ANSI / 89 mm	3"	08236	10 ft. (3.1 m)	27 lbs. (12 kg)
ANSI / 114 mm	4"	08239	13 ft. (4.0 m)	37 lbs. (17 kg)
ANSI / 168 mm	6"	08242	20 ft. (6.0 m)	64 lbs. (29 kg)
ANSI / 219 mm	8"	08245	23 ft. (7.0 m)	119 lbs. (54 kg)
PN10/16 / 89 mm	DN80	09535	10 ft. (3.1 m)	27 lbs. (12 kg)
PN10/16 / 114 mm	DN100	09536	13 ft. (4.0 m)	37 lbs. (17 kg)
PN10/16 / 168 mm	DN150	09874	20 ft. (6.0 m)	64 lbs. (29 kg)
PN10 / 219 mm	DN200	09877	23 ft. (7.0 m)	119 lbs. (54 kg)
PN16 / 219 mm	DN200	12389	23 ft. (7.0 m)	119 lbs. (54 kg)
Groove/Groove				
Pipe O.D.	Model J-1			
89 mm	3" / DN80	08237	10 ft. (3.1 m)	20 lbs. (9 kg)
114 mm	4" / DN100	08240	13 ft. (4.0 m)	27 lbs. (12 kg)
165 mm	DN150	09405	20 ft. (6.0 m)	51 lbs. (23 kg)
168 mm	6" / DN150	08243	20 ft. (6.0 m)	51 lbs. (23 kg)
219 mm	8" / DN200	08246	23 ft. (7.0 m)	106 lbs. (48 kg)

Systems with water working pressures above 175 psi (12.1 bar) may require extra-heavy pattern fittings. Model J-1 Alarm Valve flanges are Ductile Iron ANSI B16.42 Class 150 with a maximum water working pressure of 300 psi (20.7 bar). ANSI B16.42 Class 150 flanges are NOT compatible with ANSI Class 250 or Class 300 flanges. To mate the Model J-1 Alarm Check Valve with ANSI Class 250 or Class 300 flanges, use the grooved-inlet/grooved-outlet style installed with listed grooved/flanged adapters of the appropriate pressure rating. For piping with grooved connections, the grooved-inlet and/or grooved-outlet Model J-1 Alarm Check Valve may be installed with listed grooved couplings of the appropriate pressure rating.

- c. Alarm Pressure Switch: The J-1 Alarm Check Valve trim allows installation of pressure switches to operate local electric alarms and/or remote electric alarms during a sustained flow of water (such as the flow required by an open sprinkler).

Additional accessories are available and may be required for operation or supervision. Refer to the system description for complete operating trim requirements.

Trim Packages - Viking 300 psi (20.7 bar) trim is required to maintain cULus Listings and FM Approvals. Trim packages include all necessary nipples, fittings, standard trim accessories and necessary gauges.

- 300 psi (20.7 bar) vertical trim* for use when the J-1 Alarm Check Valve is installed vertically.
- 300 psi (20.7 bar) horizontal trim* for use when the J-1 Alarm Check Valve is installed horizontally.

*For optional pre-trimmed Model J-1 Alarm Check Valves, refer to the current Viking Price List or contact the manufacturer.

4. INSTALLATION

The Model J-1 Alarm Check Valve must be installed in an area not subject to freezing temperatures or physical damage. When corrosive atmospheres and/or contaminated water supplies are present, it is the owner's responsibility to verify compatibility with the Model J-1 Alarm Check Valve, trim, and associated equipment.

Prior to installing the valve, thoroughly flush the water supply piping to verify that no foreign matter is present.

The Model J-1 Alarm Check Valve may be installed in the vertical position with direction of flow up, or in the horizontal position with the access cover up.

- Verify that the appropriate trim chart and technical data for the Alarm Check Valve and associated equipment are available.
- Remove all plastic thread protectors from the openings of the Alarm Check Valve.



TECHNICAL DATA

ALARM CHECK VALVE MODEL J-1

The Viking Corporation, 210 N Industrial Park Drive, Hastings MI 49058

Telephone: 269-945-9501 Technical Services: 877-384-5464 Fax: 269-818-1680 Email: techsvcs@vikingcorp.com

3. Apply a small amount of pipe-joint compound or tape to the external threads of all pipe connections required. Take care not to allow any compound, tape, or other foreign matter inside any nipples or openings of the valve or trim components.
4. Install the Model J-1 Alarm Check Valve and trim according to current Viking Trim Charts for the valve used. Trim charts are provided with trim package and can be found in the *Viking Engineering and Design Data* book.
5. Verify that all system components are rated for the water working pressure of the system.

Placing the System in Service

When the wet-pipe system is ready to be placed in service, verify that all equipment is adequately heated and protected to prevent freezing and physical damage.

NOTE: FOR PROPER OPERATION OF THE WET SYSTEM AND TO MINIMIZE UNWANTED (FALSE) ALARMS, IT IS IMPORTANT TO REMOVE TRAPPED AIR FROM THE SYSTEM WHEN FILLING IT WITH WATER. AIR TRAPPED IN THE SYSTEM MAY ALSO CAUSE INTERMITTENT OPERATION OF THE WATER MOTOR ALARM DURING A SUSTAINED FLOW OF WATER (SUCH AS THE FLOW REQUIRED BY AN OPEN SPRINKLER OR THE SYSTEM TEST VALVE). CONSIDER INSTALLATION OF AUXILIARY VENTS TO FACILITATE VENTING.

CAUTION: OPENING OF THE WATER SUPPLY MAIN CONTROL VALVE WILL RESULT IN WATER FLOW FROM ANY OPENINGS IN THE SYSTEM.

1. Verify that auxiliary drains are closed and that the system is free of leaks.
2. Open the system test valve (and any auxiliary vents provided to facilitate removal of air from the system) to allow air to escape from the system while it is filling with water.
3. If desired, close the alarm shut-off valve to prevent local alarms from operating while filling the system.

NOTE: ALARMS AND ELECTRIC PANELS CONTROLLED BY AN ALARM PRESSURE SWITCH INSTALLED IN THE "ELECTRIC ALARM PANEL" CONNECTION PROVIDED IN THE TRIM CANNOT BE INTERRUPTED. (SEE TRIM CHART.)

4. Slowly open the water supply main control valve.
5. Allow the system to completely fill with water. Allow water to flow from the system test valve, and any other open vents provided, until all air is exhausted from the system.
6. After all air is exhausted from the system, close the system test valve and all other open vents.
7. The pressure gauge on the system side of the Alarm Check Valve Clapper should indicate water pressure equal to or greater than the water pressure indicated on the gauge located on the supply side of the clapper.
8. OPEN the Alarm Shut-Off Valve in the Alarm Valve trim, and verify that all other valves are in their normal operating position.
9. Secure all valves in their normal operating position.
10. Notify the Authority Having Jurisdiction, remote station alarm monitors, and those in the affected area that the system is in service.

5. OPERATION (Refer to Figures 1 & 2)

The Model J-1 Alarm Check Valve is manufactured with a hinged clapper (9) equipped with a torsion spring (6) to assure proper operation when the valve is installed in the horizontal position.

Minor flows, resulting from small surges, travel around the clapper through external by-pass trim to minimize false alarms. Rubber gasket (10) forms a tight seal against brass water seat (13). This seal, and the check valve installed in the external by-pass trim, serve to trap higher pressurized water in the sprinkler piping and prevent reverse flow.

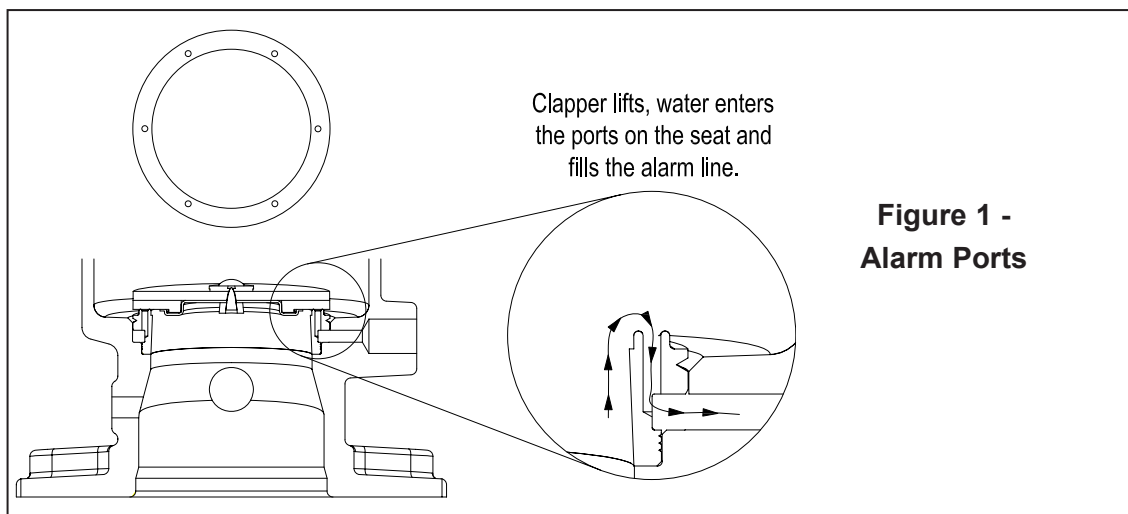



TECHNICAL DATA

ALARM CHECK VALVE MODEL J-1

The Viking Corporation, 210 N Industrial Park Drive, Hastings MI 49058

Telephone: 269-945-9501 Technical Services: 877-384-5464 Fax: 269-818-1680 Email: techsvcs@vikingcorp.com

During a sustained flow of water, such as the flow required by an open sprinkler, hinged clapper (9) moves off seat (13) to the open position. Water flows through ports in grooved seat (13), and enters the alarm port to activate alarm devices connected to the system.

Operation with Retard Chamber:

When the optional retarding chamber is used, water entering the grooved seat alarm port is directed into the retarding chamber. Temporary pressure surges or fluctuations, large enough to move the valve clapper, are automatically drained through the restricted drain.

During a sustained flow of water, such as the flow required by an open sprinkler, the clapper will be held off its seat. The retarding chamber will fill faster than water can drain through the restricted drain of the alarm valve trim. Alarm devices will be pressurized. Refer to technical data describing the Viking Retarding Chamber and alarm devices.

6. INSPECTIONS, TESTS AND MAINTENANCE

NOTICE: THE OWNER IS RESPONSIBLE FOR MAINTAINING THE FIRE-PROTECTION SYSTEM AND DEVICES IN PROPER OPERATING CONDITION.

It is imperative that the system be inspected and tested on a regular basis. The frequency of the inspections may vary due to contaminated water supplies, corrosive water supplies, and corrosive atmospheres. For minimum maintenance and inspection requirements, refer to NFPA 25. In addition, the Authority Having Jurisdiction may have additional maintenance, testing, and inspection requirements that must be followed.

WARNING: ANY SYSTEM MAINTENANCE THAT INVOLVES PLACING A CONTROL VALVE OR DETECTION SYSTEM OUT OF SERVICE MAY ELIMINATE THE FIRE-PROTECTION CAPABILITIES OF THAT SYSTEM. PRIOR TO PROCEEDING, NOTIFY ALL THE AUTHORITY HAVING JURISDICTION. CONSIDERATION SHOULD BE GIVEN TO EMPLOYMENT OF A FIRE PATROL IN THE AFFECTED AREAS.

INSPECTION

Monthly visual external inspection of Alarm Check Valves is recommended.

1. Verify that pressure gauges indicate normal water supply pressures. It is normal for the gauge on the system side of the clapper to register a higher pressure than the gauge on the supply side of the clapper because pressure surges are trapped above the clapper.
2. Check for signs of mechanical damage and/or corrosive activity. If detected, perform maintenance as required or, if necessary, replace the device.
3. Verify that valve and trim are adequately heated and protected from freezing and physical damage.
4. When equipped with variable pressure trim, verify that there is no unwanted leakage from the restricted drain of the retard chamber. It is normal for drainage to occur during pressure surges that exceed the capacity allowed through the by-pass trim.
5. Verify that the water supply main control valve is open, and that all valves are in their normal operating position and appropriately secured.

QUARTERLY TESTS

Water Flow Alarm Test

Quarterly testing of water flow alarms is recommended and may be required by the Authority Having Jurisdiction and NFPA 25.

1. Notify the Authority Having Jurisdiction, remote station alarm monitors, and those in the area affected by the test.

NOTE: AN ALARM SHUT-OFF VALVE IS PROVIDED TO SILENCE LOCAL ALARMS. NO SHUT-OFF VALVE IS PROVIDED FOR THE PRESSURE SWITCH CONNECTION INTENDED TO ACTIVATE ELECTRIC ALARM PANELS. (REFER TO J-1 ALARM CHECK VALVE TRIM CHART.)

2. To test electric alarms (if provided) and/or mechanical water motor gong (if provided), OPEN the system test valve. If freezing weather or other conditions prohibit use of the system test valve, OPEN the alarm test valve in the alarm check valve trim.

NOTE: USE OF THE ALARM TEST VALVE ALLOWS TESTING OF ALARMS WITHOUT REDUCING THE SYSTEM PRESSURE.

- a. Electric alarm pressure switches should activate.
- b. Electric local alarms should be audible.
- c. The local water motor alarm should be audible.

NOTE: WHEN USING THE SYSTEM TEST VALVE FOR THE WATER FLOW ALARM TEST, INTERMITTENT OPERATION OF THE WATER MOTOR ALARM MAY INDICATE AIR IS TRAPPED IN THE SYSTEM (REFER TO THE PLACING THE SYSTEM IN SERVICE PARAGRAPH OF SECTION 4).

- d. Verify that remote station alarm signals (if provided) were received.
3. When testing is complete, close the test valve used.
4. Verify:
 - a. All local alarms stop sounding and electric panels (if provided) reset.
 - b. All remote station alarms reset.
 - c. Retard chamber and water motor alarm supply piping has drained properly.
5. Verify that the alarm shut-off valve in the Alarm Check Valve trim is OPEN, the alarm test valve is CLOSED, and all valves are in



TECHNICAL DATA

ALARM CHECK VALVE MODEL J-1

The Viking Corporation, 210 N Industrial Park Drive, Hastings MI 49058

Telephone: 269-945-9501 Technical Services: 877-384-5464 Fax: 269-818-1680 Email: techsvcs@vikingcorp.com

their normal operating position and appropriately secured.

6. Notify the Authority Having Jurisdiction, remote station alarm monitors, and those in the affected area that testing is complete.

Main Drain Test

Semi Annual performance of the Main Drain Test is recommended and may be required by the authority having jurisdiction to verify integrity of the water supply.

1. Notify the authority having jurisdiction, remote station alarm monitors, and those in the area affected by the test.
2. Perform monthly visual inspection.
3. Verify that adequate drainage is provided for full flow from Main Drain outlet.
4. Record pressure reading from the water supply pressure gauge.
5. Fully OPEN the main drain located on the Alarm Check Valve.
6. When a full flow is developed from the main drain, record the residual pressure from the water supply pressure gauge.
7. When the test is complete, SLOWLY CLOSE the main drain.
8. Compare test results with previous flow information. If deterioration of the water supply is detected, take appropriate steps to restore adequate water supply.
9. Verify that normal water supply pressure has been restored, and that all alarm devices and valves are secured in normal operating position.
10. Notify the Authority Having Jurisdiction, remote station alarm monitors, and those in the area affected by the test that the test is complete. Record and/or provide notification of test results as required by the Authority Having Jurisdiction.

Five-Year Internal Inspection (Refer to Figure 2)

Internal inspection of Alarm Check Valves is recommended every five years unless inspections and tests indicate more frequent internal inspections are required.

1. Notify the Authority Having Jurisdiction, remote station alarm monitors, and those in the area affected that the system will be taken out of service. Consideration should be given to employment of a fire patrol in the affected areas.
2. Close the water supply Main Control Valve, placing the system out of service.
3. Open the main drain. If necessary, open the system test valve to vent and completely drain the system.
4. Use appropriate wrench to loosen and remove cover screws (15), and remove Cover/Clapper assembly (2-12).
5. Inspect water seat (13). Wipe away all contaminants, dirt, and mineral deposits. Clean any orifices in the seat that are restricted or plugged by mineral deposits. DO NOT use solvents or abrasives.
6. Inspect cover/clapper assembly (2-12) and cover gasket (14). Test hinged clapper (9) for freedom of movement and spring (6) for tension retention. Spring (6) tension should engage when the top of hinged clapper (9) is moved from perpendicular to cover (2) toward the open (flow) position. Renew or replace damaged or worn parts as required.

CAUTION: NEVER APPLY ANY LUBRICANT TO SEATS, GASKETS, OR ANY INTERNAL OPERATING PARTS OF THE VALVE. PETROLEUM-BASED GREASE OR OIL WILL DAMAGE RUBBER COMPONENTS AND MAY PREVENT PROPER OPERATION.

7. When internal inspection of the alarm check valve is complete, perform step 6 of the Maintenance paragraph in section 5 to re-install Cover/Clapper Assembly (2-12).
8. Place the wet system back in service, Refer to the Placing the System in Service paragraph in section 4.

Maintenance (Refer to Figure 2)

1. Perform steps 1 through 6 of the Five Year Internal Inspection paragraph in Section 6.
2. To remove clapper rubber (10):
 - a. Use the appropriate wrench to loosen and remove the button-head socket screw (12), hex nut (7), sealing washer (8), and rubber retainer (11).
 - b. Remove the clapper rubber (10) for inspection. If the clapper rubber shows signs of wear such as cracking, cuts, or excessively deep grooves where the rubber contacts the water seat, replace the rubber.
3. To re-install clapper rubber (10):
 - a. Place clapper rubber (10) over the center hub of the rubber retainer (11).
 - b. Position the retainer (11) (with rubber in place) against clapper (9) as shown in Figure 2.
 - c. Replace and tighten the button-head socket screw (12), sealing washer (8), and hex nut (7), as shown in Figure 2. DO NOT over-tighten.
4. To remove the clapper (9), spring (6), and/or hinge pin (4), remove hinge pin retaining rings (5), to free the hinge pin (4) for removal. After the hinge pin (4) is removed, the clapper (9) and spring (6) can be removed.
5. To re-install the clapper (9), spring (6), and/or hinge pin (4):
 - a. Verify that the clapper rubber (10) is in good condition and that it is properly installed.
 - b. Position the clapper (9) with the elongated hinge holes aligned between the holes of the hinge bracket welded inside the cover (2). The system (top) side of the clapper (9) must face the direction indicated by the flow arrow stamped inside the cover (2).
 - c. Insert the hinge pin (4) through the holes at one end of the hinge assembly. Before continuing, re-install the spring (6), using care to orient the spring as shown in Figure 2. Continue to push the hinge pin (4) through the holes at the remaining end of



TECHNICAL DATA

ALARM CHECK VALVE MODEL J-1

The Viking Corporation, 210 N Industrial Park Drive, Hastings MI 49058

Telephone: 269-945-9501 Technical Services: 877-384-5464 Fax: 269-818-1680 Email: techsvcs@vikingcorp.com

the hinge assembly.

- d. Re-install the hinge pin retaining rings (5).
6. To re-install cover/clapper assembly (2-12):
 - a. Verify that the cover gasket (14) is in position and that it is in good condition.
 - b. Slide the cover/clapper assembly (2-12) into the Alarm Valve so that the clapper rubber (10) contacts the grooved water seat (13).
 - c. Replace cover screws (15). Use the appropriate wrench to evenly cross-tighten all screws to the torque values listed in Table 2 for the valve used. DO NOT over-tighten.
7. To place the wet system back in service, refer to the Placing the System in Service paragraph in section 4.

7. AVAILABILITY

The Viking J-1 Alarm Check Valve is available through a network of domestic and international distributors. See the Viking Corp. Web site for closest distributor or contact The Viking Corporation.

8. GUARANTEES

Table 2 - Torque Values for Model J-1 Alarm Valve Cover Screws	Valve Size	Screw Size	Torque Values
	3" (DN80)	3/8" - 16 H.H.C	19 ft. lbs. (2.63 kg m)
	4" (DN100)	3/8" - 16 H.H.C	19 ft. lbs. (2.63 kg m)
	6" (DN150)	1/2" - 13 H.H.C	45 ft. lbs. (6.23 kg m)
	8" (DN200)	5/8" - 11 H.H.C	93 ft. lbs. (12.9 kg m)

For details of warranty, refer to Viking's current list price schedule or contact Viking directly.



TECHNICAL DATA

ALARM CHECK VALVE MODEL J-1

The Viking Corporation, 210 N Industrial Park Drive, Hastings MI 49058
 Telephone: 269-945-9501 Technical Services: 877-384-5464 Fax: 269-818-1680 Email: techsvcs@vikingcorp.com

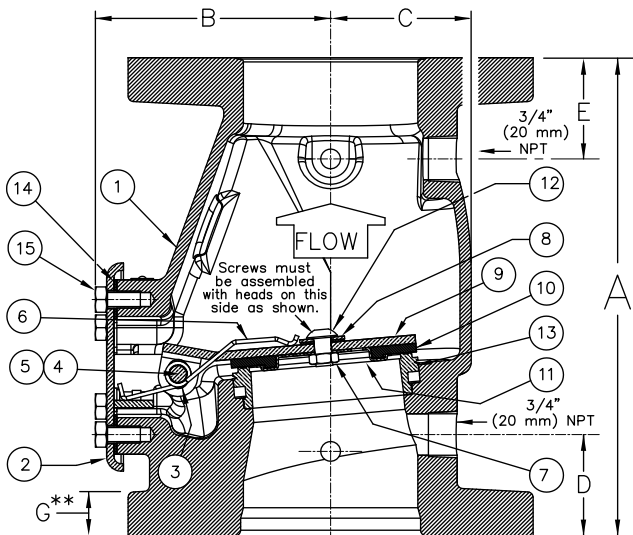

SIZE	A	B	C	D	E	F*	G**
3" (DN80)	10-1/8" (257)	4-13/16" (122.2)	2-11/16" (68.3)	2-9/32" (58.1)	2-9/32" (58.1)	7-7/8" (200)	25/32" (20)
4" (DN100)	10-5/8" (269.9)	5-3/16" (131.8)	3-1/8" (79.4)	2-1/4" (57.2)	2-1/4" (57.2)	9" (228.6)	15/16" (23.81)
6" (DN150)	13-3/8" (340)	6-13/16" (173.3)	4-1/16" (103.2)	2-1/4" (57.2)	2-1/4" (57.2)	11" (279.4)	1" (25.4)
8" (DN200)	17" (431.8)	8-13/16" (223.4)	5" (127)	2-1/2" (63.4)	2-7/8" (73.0)	13-1/2" (342.9)	1-1/8" (28.58)

Dimensions shown in parentheses are millimeters.

* Flanges are optional.
 Valve is available Flg X Flg, Flg X Grv, or Grv X Grv.

** 4", 6", and 8" valves are manufactured with sculptured flanges.
 Dimension indicates thickness of flange at bolt holes.

Figure 2 - Replacement Parts

ITEM NO.	PART NUMBERS				DESCRIPTION	MATERIAL	NO. REQ'D			
	3" (DN80)	4" (DN100)	6" (DN150)	8" (DN200)			3"	4"	6"	8"
1	--	--	--	--	Body	Ductile Iron, ASTM A536 (65-45-12)	1	1	1	1
2	--	--	--	--	Cover Assembly	E-Coated HSLA Steel A715 and Stainless Steel UNS-S30400	1	1	1	1
3	07576	07576	07576	--	Bushing	Lubricomp 189 Ryton	2	2	2	--
4	05355A	04900A	04991A	05334A	Clapper Hinge Pin	Stainless Steel UNS-S30400	1	1	1	1
5	05445A	05445A	05445A	05369A	Hinge Pin Retaining Ring	Stainless Steel UNS-S15700	2	2	2	2
6	06021B	05939B	05940B	05952B	Spring	Stainless Steel UNS-S30200	1	1	1	1
7	08159	08159	--	--	Clapper Hex Nut 3/8"-24 UNF	Stainless Steel UNS-S30400	1	1	--	--
			--	08144	08144	Clapper Hex Nut 1/2"-20 UNF	Stainless Steel UNS-S30400	--	--	1
8	08158	08158	--	--	Sealing Washer 3/8" x 1" O.D.	EPDM and Stainless Steel	1	1	--	--
			--	08143	08143	Sealing Washer 1/2" x 1-1/8" O.D.	EPDM and Stainless Steel	--	--	1
9	*	*	*	*	Clapper	Teflon® Coated HR Steel UNS-G10180	1	1	1	1
10	*	*	*	*	Clapper Rubber	EPDM	1	1	1	1
11	*	*	*	*	Clapper Rubber Retainer	Stainless Steel UNS-S30400	1	1	1	1
12	18667	18667	--	--	Screw, Button Head, Socket 3/8"-24 x 1/2" (12.7 mm) lg.	Stainless Steel UNS-S30400	1	1	--	--
	--	--	10308	--	Screw, Button Head, Socket 1/4"-20 x 3/4" (19.0 mm) lg.	Stainless Steel UNS-S30400	--	--	1	--
	--	--	--	10686	Screw, Button Head, Socket 1/2"-20 x 7/8" (22.2 mm) lg.	Stainless Steel UNS-S30400	--	--	--	1
13	--	--	--	--	Seat	Brass UNS-C84400	1	1	1	1
14	05354B	04649B	04992B	05339C	Cover Gasket	EPDM, ASTM D2000	1	1	1	1
15	01517A	01517A	--	--	H.H.C. Screw 3/8"-16 x 3/4" (19.0 mm) lg.	Steel, Zinc Plated	4	6	--	--
	--	--	04993A	--	H.H.C. Screw 1/2"-13 x 7/8" (22.2 mm) lg.	Steel	--	--	6	--
	--	--	--	01922A	H.H.C. Screw 5/8"-11 x 1-1/4" (31.8 mm) lg.	Steel, Zinc Plated	--	--	--	6

-- Indicates replacement part not available

* Indicates replacement part only available in a Sub-Assembly listed below.

SUB-ASSEMBLIES

3, 7-12	08518	08519	08520	08521	Clapper Assembly
7, 8, 10-12, 14	08522	08523	08524	08525	Replacement Rubber Kit

RETAED CHAMBER

BRAND : **VIKING**
MANUFACTURER : VIKING CORPORATION
COUNTRY : USA.
MODEL : **C-1**
TYPE : HYDRAULICALLY OPERATED
APPROVED : UL/FM
WORKING PRESSURE RANGE : 300 PSI.

MATERIAL LIST

BODY : DUCTILE IRON, BLACK FINISH
BUSHINGS : CAST IRON



TECHNICAL DATA

RETARD CHAMBER
MODEL C-1

The Viking Corporation, 210 N Industrial Park Drive, Hastings MI 49058

Telephone: 269-945-9501 Technical Services: 877-384-5464 Fax: 269-818-1680 Email: techsvcs@vikingcorp.com

1. DESCRIPTION

The Viking Model C-1 Retard Chamber is a surge tank used with Viking Alarm Check Valves to reduce the possibility of false alarms due to changes in the water supply pressure.

Features

1. Ductile iron body
2. Self draining
3. Required Accessories:
 - a. P/N 01611A - 1/8 inch (3.2 mm) Drain Restriction (included in Viking Alarm Check Valve Trim Sets designed for use with "variable pressure" water supplies).
4. Optional Accessories:
 - a. P/N 01973A - Circuit closer vent assembly (Required when an electric Alarm Pressure Switch is installed without a Water Motor Alarm.)
 - b. Alarm Devices: A Water Motor Alarm and/or electric Alarm Pressure Switch, with approved connected alarms, are required for a complete system.



2. LISTINGS AND APPROVALS



UL_{US} Listed: VPLX and VPLX7 - 300 psi (20.7 bar) MWP



FM Approved: Waterflow Alarm Valves - 300 psi (20.7 bar) MWP



New York City Board of Standards and Appeals: Calendar Number 219-76-SA - 250 psi (17.2 bar) MWP

VdS Approved: Wet Alarm Valve Stations - 250 psi (17.2 bar) MWP



LPCB Approved - 250 psi (17.2 bar) MWP

3. TECHNICAL DATA

Specifications:

Pressure Rating - 300 psi (20.7 bar) water working pressure.

Factory tested hydrostatically to 600 psi (41.4 bar).

Connections: 1/2" (15 mm) NPT inlet and 3/4" (20 mm) NPT outlet.

Capacity: 1 Gallon (4 Liters) Approx.

Material Standards:

Body: Ductile Iron 65-45-12.

Bushings: Cast Iron UNS-F12102

Coating: Viking black E-coat Spec SPF02 W01

Ordering Information:

Part Number - 05904B

Shipping Weight - 22 lbs. (10 kg.)

Available Since - 1986

Viking Technical Data may be found on
The Viking Corporation's Web site at
<http://www.vikinggroupinc.com>.
The Web site may include a more recent
edition of this Technical Data Page.

4. INSTALLATION

1. The Retard Chamber and associated trim must be installed as shown on the Viking Alarm Check Valve Trim Sheets. The trim size and arrangement shown on Viking Trim Charts is required for proper operation.
2. Circuit Closer Vent Trim must be galvanized steel unless other materials are specified in the Technical Data for the system used.
3. The 1/8 inch Drain Restriction must be installed in the Retard Chamber drain piping. The alarm supply trim piping must be restricted as shown on Viking Alarm Check Valve Trim Charts. Model J-1 Alarm Check Valve trim requires a 7/32" Restricted Orifice (Part No. 06980A).
4. The Retard Chamber must drain automatically to a non-pressurized drain.
5. For the Retard Chamber to properly drain, it must be vented. This is normally accomplished through the Water Motor Alarm connection. However, when the line to the Water Motor is trapped or an electric Alarm Pressure Switch is used without the Water Motor Alarm, Circuit Closer Vent Trim must be installed and kept clean to allow the Retard Chamber to drain.
6. Verify that all system components are rated for the water working pressure of the system.

5. OPERATION

When the clapper of the Alarm Check Valve opens, water flows through the restricted alarm supply piping into the inlet of the Retard Chamber. The Retard Chamber begins to fill while simultaneously draining through the 1/8 inch (3.2 mm) Drain Restriction.

**TECHNICAL DATA****RETARD CHAMBER
MODEL C-1**

The Viking Corporation, 210 N Industrial Park Drive, Hastings MI 49058

Telephone: 269-945-9501 Technical Services: 877-384-5464 Fax: 269-818-1680 Email: techsvcs@vikingcorp.com

During a sustained flow of water, the Retard Chamber fills faster than water can drain through the Drain Restriction. Pressurized water fills the Retard Chamber and pressurizes the Water Motor Alarm and/or Alarm Pressure Switch. Pressure surges insufficient to overcome the volume and drain capacity of the Retard Chamber will not activate an alarm. Two Retard Chambers may be installed in series to combat false alarms from systems subject to excessive pressure surges.

6. INSPECTION, TESTS AND MAINTENANCE

NOTICE: THE OWNER IS RESPONSIBLE FOR MAINTAINING THE FIRE PROTECTION SYSTEM AND DEVICES IN PROPER OPERATING CONDITION. THE VIKING MODEL C-1 RETARD CHAMBER AND ASSOCIATED PIPING MUST BE KEPT FREE OF FOREIGN MATTER, FREEZING CONDITIONS, AND PHYSICAL DAMAGE THAT COULD IMPAIR ITS OPERATION. THE FREQUENCY OF INSPECTIONS MAY VARY DUE TO CONTAMINATED OR CORROSIVE WATER SUPPLIES, CORROSIVE ATMOSPHERES, OR ACTIVITY AROUND THE DEVICE. ALARM DEVICES AND OTHER CONNECTED EQUIPMENT MAY REQUIRE MORE FREQUENT INSPECTIONS. REFER TO APPLICABLE CODES, SYSTEM DESCRIPTION, AND TECHNICAL DATA FOR THE EQUIPMENT USED.

After installation and prior to each Waterflow Alarm Test:

1. Verify that the Alarm Check Valve and Retard Chamber are trimmed exactly as shown on Viking Trim Sheets with no deviations. The trim size and arrangement is required for proper operation.
2. Inspect and clean the 1/8 inch (3.2 mm) Drain Restriction at least annually.

After each operation and Waterflow Alarm Test:

1. Verify that the Retard Chamber and alarm line piping has drained completely and associated alarm equipment has properly reset.
2. Refer to Technical Data for the Water Motor Alarm, Alarm Pressure Switch, and other associated equipment for additional testing and maintenance requirements.

WARNING: ANY SYSTEM MAINTENANCE INVOLVING PLACING A CONTROL VALVE OR ALARM SYSTEM OUT OF SERVICE MAY ELIMINATE THE FIRE PROTECTION CAPABILITIES OF THAT SYSTEM. PRIOR TO PROCEEDING, NOTIFY ALL AUTHORITIES HAVING JURISDICTION. CONSIDERATION SHOULD BE GIVEN TO EMPLOYMENT OF A FIRE PATROL IN THE AFFECTED AREAS.

For minimum maintenance requirements, refer to NFPA 25. In addition, the Authority Having Jurisdiction may have additional maintenance requirements that must be followed.

7. AVAILABILITY

The Viking Retard Chamber is available through a network of domestic and international distributors. See the Viking Corp. Web site for closest distributor or contact The Viking Corporation.

8. GUARANTEES

For details of warranty, refer to Viking's current list price schedule or contact Viking directly.



TECHNICAL DATA

RETARD CHAMBER MODEL C-1

The Viking Corporation, 210 N Industrial Park Drive, Hastings MI 49058

Telephone: 269-945-9501 Technical Services: 877-384-5464 Fax: 269-818-1680 Email: techsvcs@vikingcorp.com

Figures 1 & 2 Notes

1. Connect alarm line piping to the 3/4" (20 mm) outlet of the Retard Chamber. When using a Water Motor Alarm, a strainer is required. When using an electric Alarm Pressure Switch only, or when the alarm line piping is trapped, Circuit Closer Vent Trim is required.
2. Items marked with * are included in the Viking Circuit Closer Vent Trim sets.

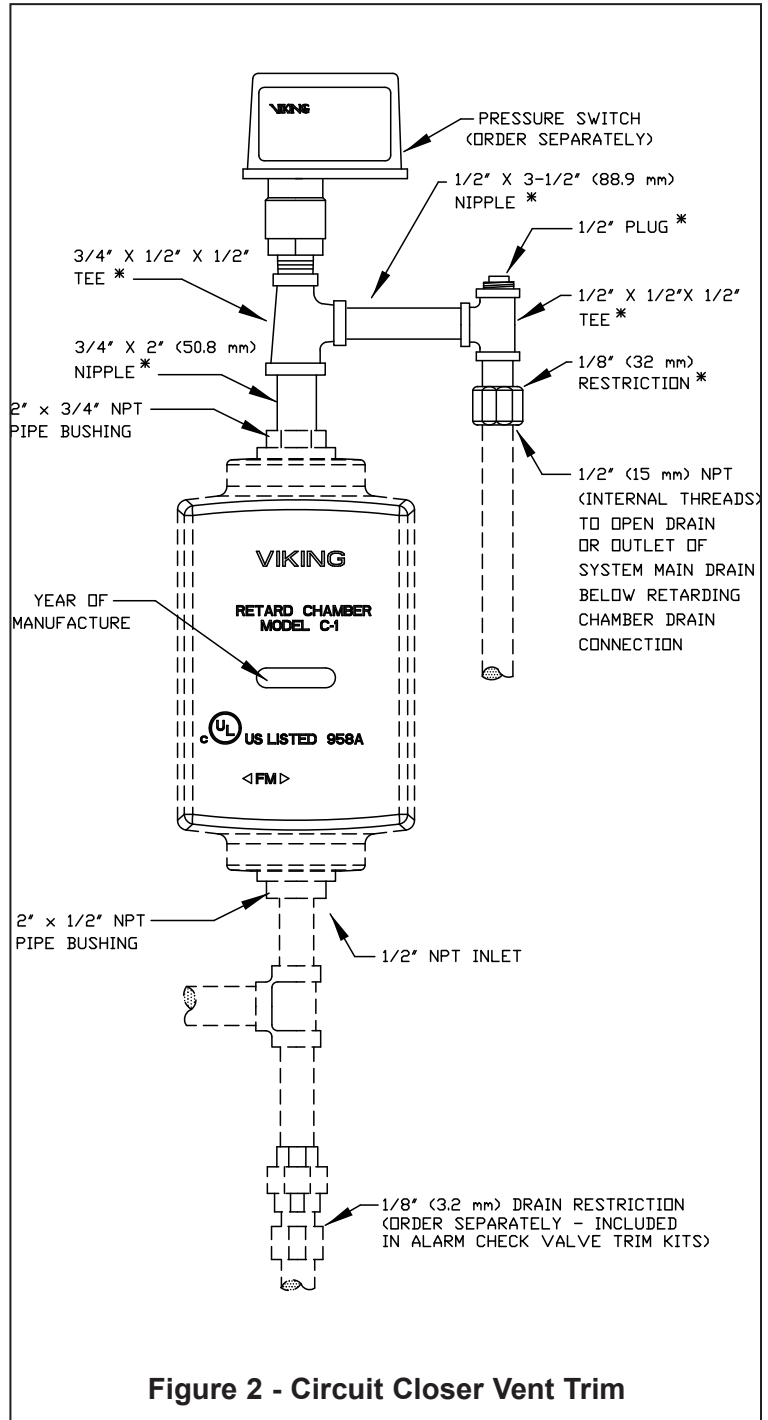
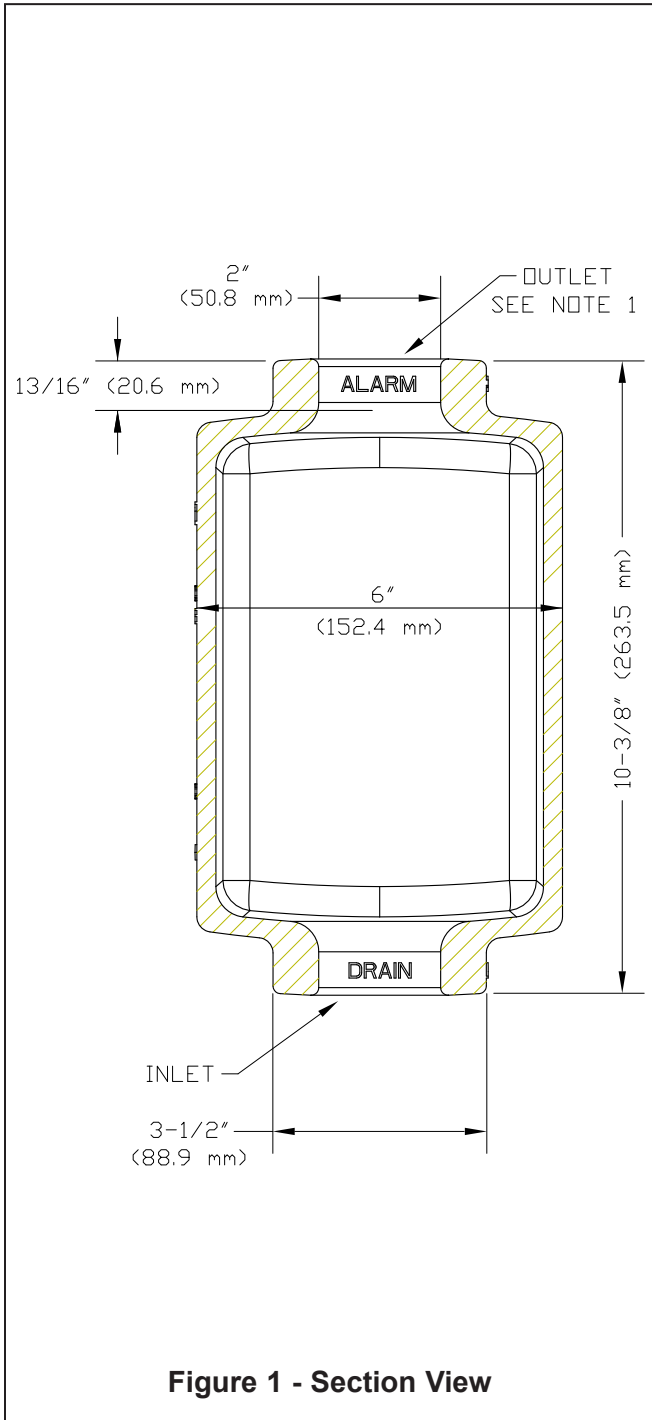

WATER MOTOR ALARM

BRAND : **VIKING**
MANUFACTURER : VIKING CORPORATION
COUNTRY : USA.
MODEL : **F-2**
TYPE : HYDRAULICALLY OPERATED
APPROVED : UL/FM
WORKING PRESSURE RANGE : 175 PSI.

MATERIAL LIST

GONG : ALUMINUM
TRIM : GALVANIZED STEEL NIPPLES AND
STAINLESS STEEL



TECHNICAL DATA

WATER MOTOR ALARMS

The Viking Corporation, 210 N Industrial Park Drive, Hastings MI 49058

Telephone: 269-945-9501 Technical Services: 877-384-5464 Fax: 269-818-1680 Email: techsvcs@vikingcorp.com

1. DESCRIPTION

The Viking water motor alarms are mechanical devices actuated by a flow of water. They are designed to sound a continuous alarm while a sprinkler system operates. An alarm is a required component of every sprinkler system having more than 20 sprinklers.

A. Features

1. The water motor alarms are tapped 3/4" NPT on the inlet and 1" NPT on the drain outlet.
2. The water motor alarm package includes a drive shaft 16-3/4" (425 mm) long for walls 14" (356 mm) thick or less. A special extension shaft is available for walls up to 30-1/4" (768 mm) thick.
3. The package also includes the required 3/4" (20 mm) NPT strainer for installation on the alarm line.
4. Rated water working pressure of Model F-2 is 250 PSI (17.2 bar).

B. Accessories: (order separately)

1. Extension Mounting Cup: Viking Part Number 05957B, Material: 14-Gauge Cold Rolled Steel, UNS-G10080, coated with black E-coat. The extension mounting cup is required when the wall thickness is less than 3" (76.2 mm). Refer to "INSTALLATION" instructions. See Figure 2.
2. Closure Plate: For use with Model F-2 only, Viking Part Number 05820B, Material: 16-Gauge Galvanized Steel, UNS-G10080. The closure plate is required when the Model F-2 Water Motor Alarm gong is mounted on an irregularly surfaced wall. It serves to prevent birds from entering the inside of the gong. The closure plate also serves as a mounting plate for sheet metal walls. Refer to "INSTALLATION" instructions. See Figure 2.
3. Special Extension Shaft: Viking Part Number 03312B, Material: Stainless Steel, UNS-S30400. The extension shaft is required when the F-2 or G-2 Water Motor Alarm is installed on walls from 14" (356 mm) to 30-1/4" (768 mm) thick.



2. LISTINGS AND APPROVALS

Model F-2:



cULus Listed - VPLX



FM Approved - Water Motor Gongs



LPCB Approved



CE - Standard EN 12259-4, EC-certificate of conformity 1725-CPD-H0001

New York City Board of Standards and Appeals - Calendar No. 219-76-SA

Model G-2:



VdS



CE - Standard EN 12259-4, EC-certificate of conformity 1725-CPD-H0001

The 07862 and 07868 Water Motor Alarms Model F-2 and Model G-2 conform to the provision of EN12259-4 standard.

EN12259-4 approvals are provided by: FM Approvals Ltd. 1 Windsor Dials Windsor, Berkshire, UK. SL4 1 RS

Approval Certificate No. issued February 15, 2010.

Viking Technical Data may be found on
The Viking Corporation's Web site at
<http://www.vikinggroupinc.com>.
The Web site may include a more recent
edition of this Technical Data Page.

3. TECHNICAL DATA

Specifications

Available since 1991

Shipping Weight: Model F-2: 11 lbs. (5.0 kg); Model G-2: 13 lbs. (5.9 kg)

Water working pressure: Rated to 175 PSI (12 bar)

Material Standards (See Figure 3)

Viking E-coat Spec: SPF02 W01

Ordering Information

Model F-2, Viking Part No. 07862

Model G-2, Viking Part No. 07868

4. INSTALLATION

Locate the water motor on an exterior wall as close as practical to the valve being monitored for water flow. A 3/4" (20 mm) strainer (included) is required on the alarm line as close as possible to the alarm outlet of the valve being monitored for water flow (or outlet of the retard chamber, if used). The location must be easily accessible for cleaning.



TECHNICAL DATA

WATER MOTOR ALARMS

The Viking Corporation, 210 N Industrial Park Drive, Hastings MI 49058

Telephone: 269-945-9501 Technical Services: 877-384-5464 Fax: 269-818-1680 Email: techsvcs@vikingcorp.com

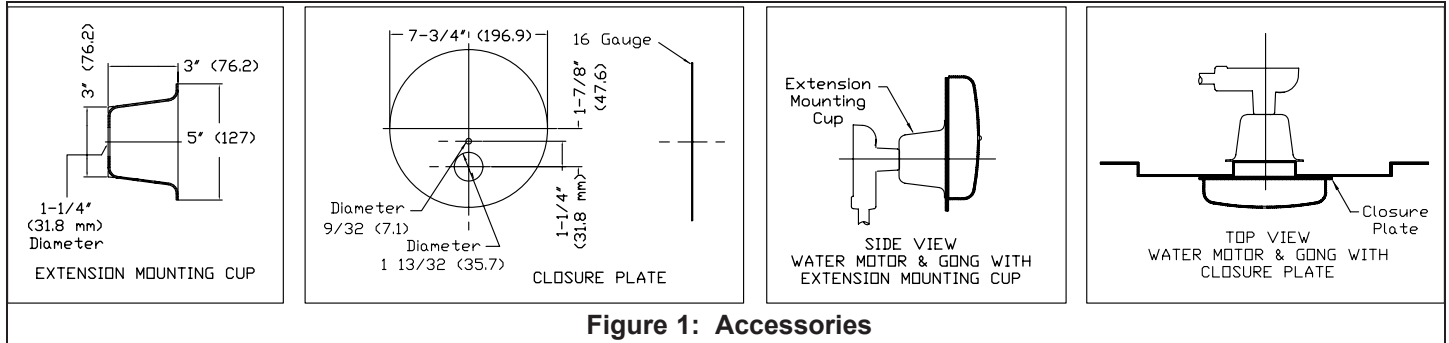

Figure 1: Accessories

- A. Cut a 1-7/16" (36.5 mm) minimum to 1-5/8" (41.3 mm) maximum diameter hole in the building wall to accommodate the 3/4" (20 mm) galvanized spacer pipe. (Note: Spacer pipe is NOT included in Water Motor Alarm Package). The hole through the wall must be level or pitched slightly downward toward the water motor.
- B. Measure the wall thickness.
- C. Cut and thread the spacer pipe to a length equal to: The wall thickness minus 1" (25.4 mm). If the extension mounting cup is used, add an additional 3" (76 mm) to the spacer pipe.
- D. Cut the drive shaft (10) to a length equal to: The total wall thickness plus 2-3/4" (70 mm). If extension mounting cup is used, add an additional 3" (76 mm).
- E. File the drive shaft to provide a 3/32" (2.4 mm) x 45° chamfer on both corners of both ends. File off all burrs and insert the drive shaft into the hole of the striker arm shaft.
- F. Slide the spacer pipe over the shaft and thread the end of the spacer pipe into the gong support assembly coupling (12).
- G. Slide the closure plate (if used) over the free end of the spacer pipe, up to the back of the gong. If desired, the closure plate may be fastened to the gong support by using the 9/32" (7.14 mm) diameter hole in the gong support. Use only a flat or round headed fastener that will not interfere with striker arm movement.
- H. Position the support assembly on the exterior wall surface by sliding the free threaded end of the spacer pipe into the hole from outside the building.
- I. On the inside surface of the wall: Slide the wall plate provided (9), over the free threaded end of the spacer pipe. (If an extension mounting cup is used, place it over the end of the spacer pipe with the flared end toward the wall before sliding the wall plate into position).

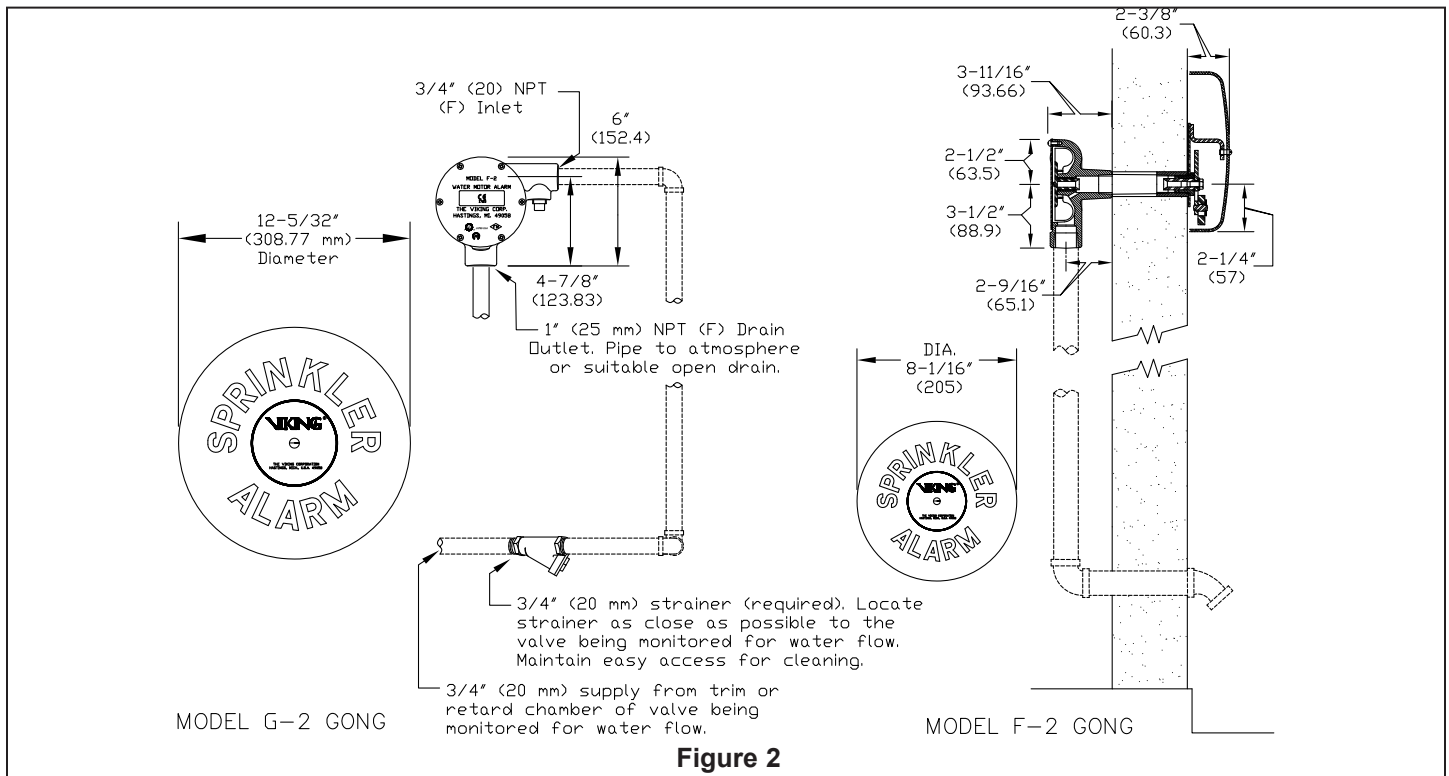

Figure 2



TECHNICAL DATA

WATER MOTOR ALARMS

The Viking Corporation, 210 N Industrial Park Drive, Hastings MI 49058

Telephone: 269-945-9501 Technical Services: 877-384-5464 Fax: 269-818-1680 Email: techsvcs@vikingcorp.com

- J. Remove the plastic thread protectors from the threaded openings in the body of the water motor.
- K. Attach the water motor assembly by threading the body (3) onto the free threaded end of the spacer pipe. The chamfered ends of the drive shaft allow it to slide into position as the water motor body is threaded onto the spacer pipe. When the assembly is properly tightened, the water motor should be positioned with the 1" (25 mm) NPT drain outlet facing downward and the 3/4" (20 mm) NPT alarm line inlet horizontal. See Figures 1 and 3.
- L. Attach the gong, the flat washer, and the gong label (16, 17, and 18) to the gong support installed on the exterior surface of the wall, with the 5/16-18 x 12" (13 mm) screw (19). Note: The flat washer must be installed between the gong and the gong support (17).
- M. With galvanized, brass, or other approved corrosion-resistant piping, not less than 3/4" (20 mm) diameter, connect the water motor inlet to the alarm outlet of the waterflow detecting device. A 3/4" (20 mm) strainer (included) is required on the alarm line as close as possible to the alarm outlet of the waterflow detecting device (or outlet of the retard chamber if used). The location must be easily accessible for cleaning.
- N. The drain outlet of the impeller housing must discharge to an open drain. Care shall be taken to keep the drain line clean at all times.
- O. Note: A water motor drain line that:
 1. Has too many fittings, and/or
 2. Has a very short length of pipe between the 1" (25 mm) outlet and the first elbow in the water motor drain pipe, and/or
 3. Is very long may result in slow drainage and reduced water motor speed. This condition can be remedied by increasing the drain pipe diameter, increasing the length of pipe to the first elbow, and/or pitching the pipe toward the discharge location.

5. OPERATION (See Figure 3)

When a sprinkler system is activated, water flows from the alarm outlet of the valve, through the 3/4" (20 mm) strainer and alarm line piping, into the inlet of the water motor. From the 1/8" inlet orifice, the water flows through a nozzle (4), which restricts the flow into a pressurized stream directed onto the impeller (7). Force from the water stream turns the impeller and drive shaft (10), causing the striker arm (20) to rotate. The striker (25) impacts against the gong (16), producing a continuous alarm. A minimum of 5 PSI (.34 bar) is required at the nozzle to cause a continuous alarm. When properly installed, the Model F-2 Water Motor Alarm produces the required 90 decibel output and the Model G-2 produces 100 decibels. After passing through the water motor, the water is discharged through a 1" (25 mm) drain outlet in the bottom of the impeller housing. The discharged water must be piped through the wall to atmosphere or to a suitable open drain.

6. INSPECTIONS, TESTS AND MAINTENANCE

Weather-resistant materials are used in the construction of the water motor alarm. At regular intervals, examine and test the water motor to ensure that the nozzle and drain line are clean and free of obstruction, and that the alarm functions properly. Also, at regular intervals and before disassembly of the water motor, clean and inspect the alarm line strainer located at the alarm outlet of the waterflow detecting device, or the outlet of the retard chamber, if used. (Note: Some retard chambers may be equipped with a strainer built in). For minimum maintenance and inspection requirements, refer to NFPA 25. In addition, the Authority Having Jurisdiction may have additional maintenance, testing, and inspection requirements that must be followed. Before proceeding with disassembly of the water motor alarm, notify the Authority Having Jurisdiction and occupants of the area covered by the system affected. Take all appropriate precautions. The water motor alarm will be disabled during disassembly.

A. Water Motor Disassembly (See Figure 3)

1. Isolate the water motor alarm by closing the alarm line valve in the trim of the waterflow detecting device. (Refer to appropriate technical data for the system used.)
2. Remove pipe plug (5).
3. Remove all round head machine screws (1) from the water motor cover.
4. Separate the cover (2) and the gasket (6) from the housing (3).
5. Remove the impeller (7).
6. Inspect and, if necessary, carefully clean the nozzle (4) with a wire or pipe cleaner brush.
7. Flush the nozzle way and drain line with water or compressed air.

B. Water Motor Re-Assembly

1. Re-install the pipe plug (5).
2. Re-install the impeller (7).
3. Replace cover gasket (6) and attach cover (2) by using round head machine screws (1).
4. Open the alarm line valve.
5. Test the water motor alarm.
6. When test is complete and water motor alarm operation is satisfactory, place the alarm line valve in the proper "alarm" position. Reset and return the affected systems to service.

7. AVAILABILITY

Viking Water Motor Alarms are available through a network of domestic and international distributors. See the Viking Corp. Web site for closest distributor or contact The Viking Corporation.

8. GUARANTEES

For details of warranty, refer to Viking's current list price schedule or contact Viking directly.



TECHNICAL DATA

WATER MOTOR ALARMS

The Viking Corporation, 210 N Industrial Park Drive, Hastings MI 49058

Telephone: 269-945-9501 Technical Services: 877-384-5464 Fax: 269-818-1680 Email: techsvcs@vikingcorp.com

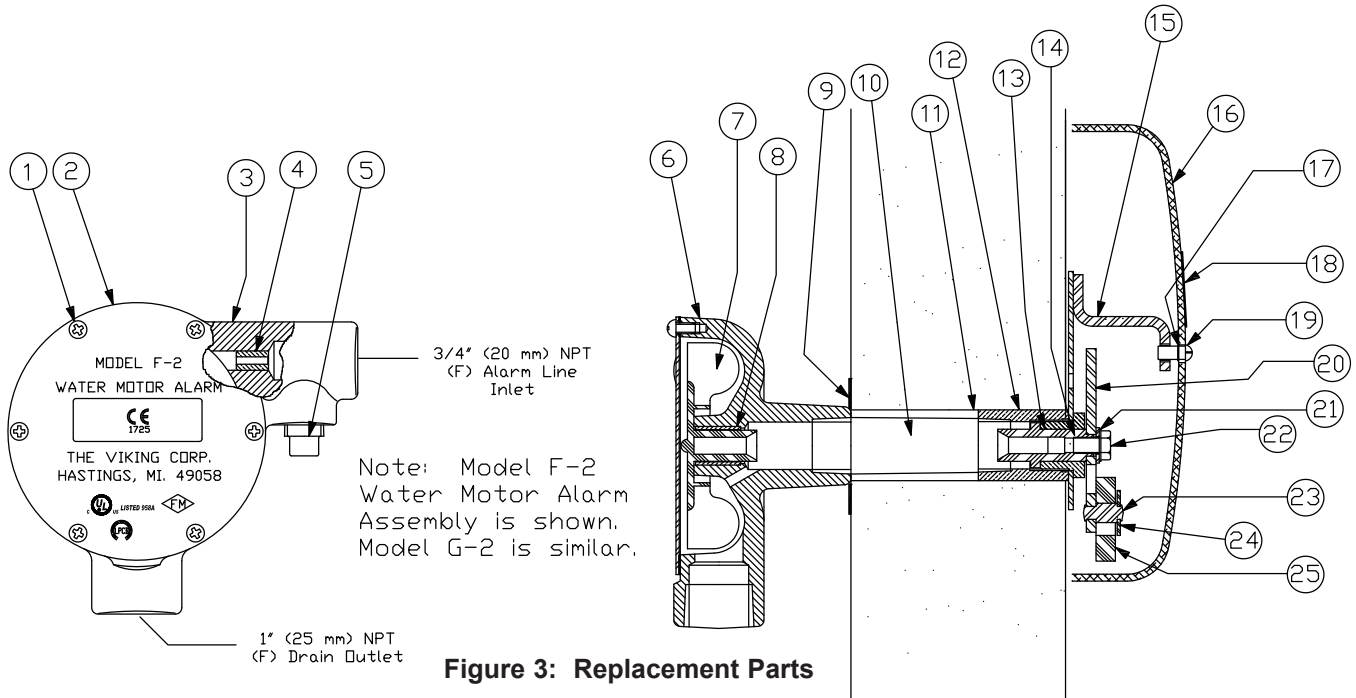

Figure 3: Replacement Parts

ITEM NO.	PART NUMBER		DESCRIPTION	MATERIAL	NO. REQ'D
	F-2	G-2			
1	*	*	Screw, R. H. Self-tap #10-24 x 3/8" lg.	Zinc Plated Steel	6
2	07867	07870	Cover	Steel	1
3	*	*	Housing	Cast Iron	1
4	*	*	Nozzle	Brass	1
5	01925S	01925S	1/2" Pipe Plug	Cast Iron	1
6	02550B	02550B	Cover Gasket	Cellulose/Nitrile/Glass Blend	1
7	02547C	02547C	Impeller	Delrin	1
8	*	*	Bearing	Brass: Sintered Bronze	1
9	05603A	05603A	Wall Plate	Galvanized Steel	1
10	05604B	05604B	Drive Shaft	Stainless Steel	1
11	--	--	3/4" Pipe (C.O.J.) not furnished	Galvanized Steel	1
12	*	*	Coupling	Brass	1
13	02556B	02556B	Striker Arm Shaft	Celcon Glass Filled	1
14	*	*	Bearing	Brass	1
15	*	*	Gong Support	Stainless Steel	1
16	05821C	06508C	Gong	Aluminum	1
17	02766A	02766A	Flat Washer, 11/32" ID x 11/16" ID x 1/16"	Stainless Steel	1
18	05768A	06505C	Gong Label	Aluminum (F-2), Vinyl (G-2)	1
19	--	--	Screw, B.H. Slotted, 5/16-18 x 1/2" lg.	Stainless Steel	1
20	*	*	Striker Arm	Stainless Steel	1
21	--	--	Flat Washer, 11/32" ID x 11/16" OD x 1/16"	Stainless Steel	1
22	--	--	Screw, H.H. Self-tap 5/16-18 x 1/2" lg.	Zinc Plated Steel	1
23	*	*	Striker Pin	Stainless Steel	1
24	*	*	Striker Arm Washer	Stainless Steel	1
25	*	*	Striker	Canvas Phenolic	1

--Indicates replacement part not available

*Indicates replacement part only available in a Sub-Assembly listed below

SUB-ASSEMBLIES

1-8	07863	07869	Motor Assembly
20, 23-25	02558B	02558B	Striker Arm Assembly
12-15, 20-25	05606C	06506C	Support Assembly