



# SEMI-AUTOMATIC HOSE RACK ASSEMBLY

An immediate and readily available means of controlling and suppressing fire by one person. The assemblies are capable of accepting the nationally recognized standard for Class II or Class III Service at the outlet of the valve.

## NFPA/FEMA CLASS OF SERVICE

CLASS I FIRE SERVICE ONLY

CLASS II OCCUPANT USE

CLASS III FIRE SERVICE OR OCCUPANT USE

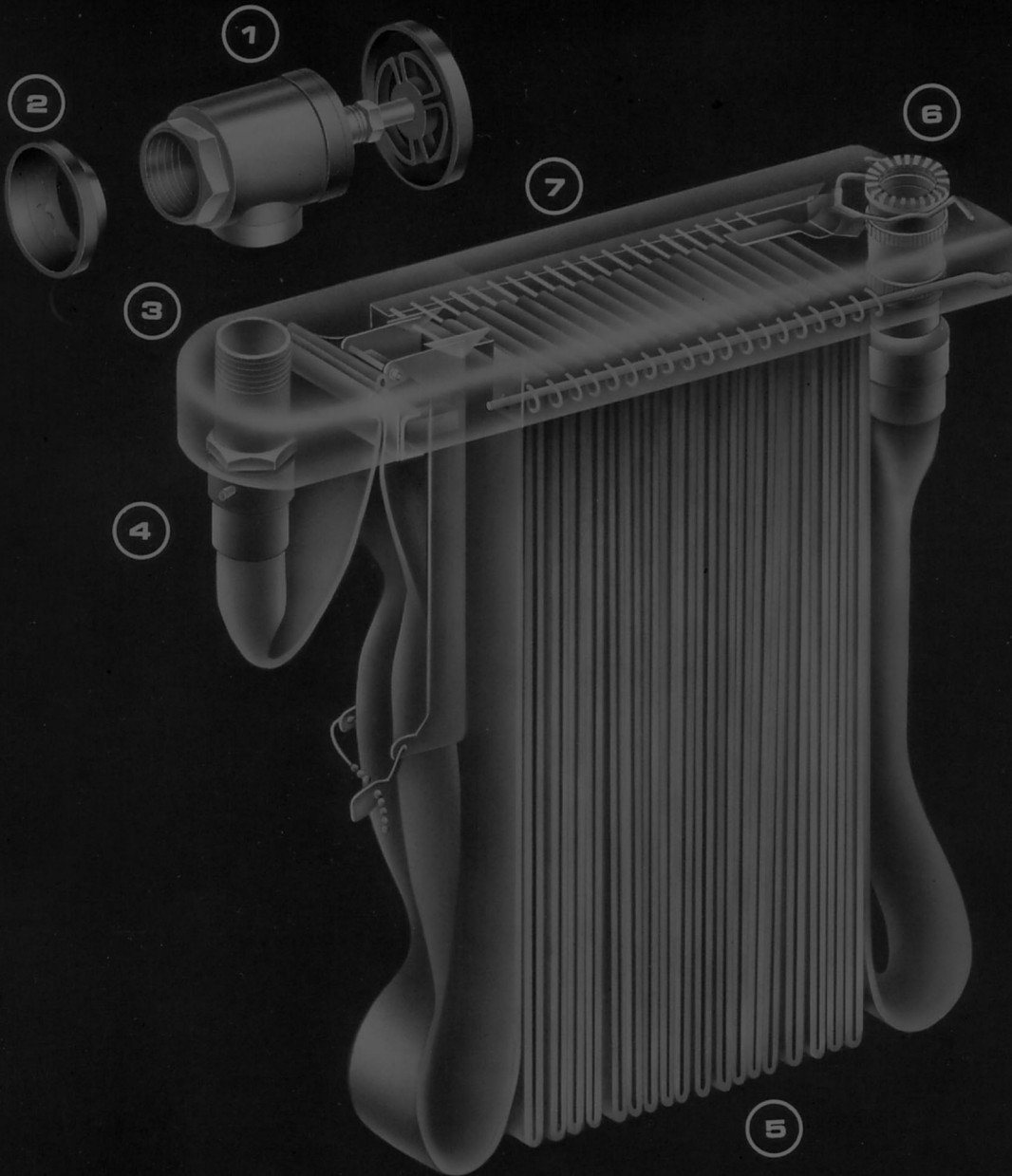

- ① **VALVE**  
Connection to standpipe. Controls water flow and pressure. Refer to Section 4000.
- ② **ESCUTCHEON**  
To conceal pipe entry into cabinet.
- ③ **RACK NIPPLE**  
Supports the hose rack and allows directional deployment of hose. Provide local fire department thread.
- ④ **COUPLING**  
Allows watertight attachment of hose to nipple. Refer to page 2-11.
- ⑤ **HOSE**  
A lightweight, durable, compact, and readily deployed hose that is testable and easily folded for rack storage. Refer to pages 2-9 and 10.
- ⑥ **FOG NOZZLE**  
Directs water flow to extinguish fire. The nozzle pattern control permits fog, straight stream or shut off positions. Refer to pages 2-13 and 14.
- ⑦ **SEMI-AUTOMATIC HOSE RACK**  
Provides storage for folded hose and nozzle. The water retention device provides one-person operation. Inspection seal indicates readiness of the assembly. Refer to page 2-4.

1. Open valve wide.

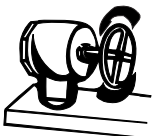

2. Pull hose completely off rack.

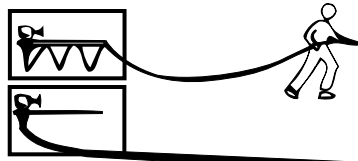

3. Water will come on when hose is free.



Call Potter-Roemer for current listings and approvals. Dimensions are subject to manufacturer's tolerance and change without notice. We assume no responsibility for use of superseded or void data.

# 1 1/2" / 3.8 cm HOSE RACK ASSEMBLIES

POTTER-ROEMER



A Division of Smith Industries, Inc.

**FUNCTION: For Class II Service.** Used to provide an immediate and more efficient means of fire control. The assembly is capable of one-person operation and accepting the nationally recognized standard of 100 GPM/378.5 lpm at 65 PSI/4.5 bars at the outlet of the valve.

**REGULARLY FURNISHED:**

- Model 4070** U/L-◀ FM ▶ Angle Valve Rough Brass 300 PSI/20.7 bars
- Model 2750** Escutcheon
- Model 2755** Satin Brass Hose Rack Nipple
- Model 2930** Satin Brass Pin Lug Coupling
- Model 2915** ◀ FM ▶ Lined 500 PSI/34.5 bars Acceptance Pressure Test Polyflex Hose
- Model 2962** U/L - ◀ FM ▶ Satin Brass Fog Nozzle
- Model 2792** U/L - ◀ FM ▶ Red Glossy Polyester Coated Steel Hose Rack
- Model 1985** Instructional Label

Model No.	Hose Length ft. m	Valve Size in. cm	Hose Dia. in. cm	Dimensions			
				A in. cm	B in. cm	C in. cm	D in. cm
2505	50 15.2	1 1/2 3.8	1 1/2 3.8	23 1/2 59.7	22 55.8	18 45.7	4 10.2
2507	75 22.8	1 1/2 3.8	1 1/2 3.8	26 66	24 1/2 62.2	18 45.7	4 10.2
2510	100 30.4	1 1/2 3.8	1 1/2 3.8	31 78.7	29 1/2 74.9	18 45.7	4 10.2

Add 4" / 10.2 cm to hose rack assembly dimension "C" for Model 2926 PR-Superflex Hose.

## OPTIONAL FINISHES

	Rack	Valve	Trim
- A	Red Finish	Rough Brass	Polished Brass
- B	Red Finish	Polished Brass	Polished Brass
- C	Polished Chrome Plated	Rough Chrome Plated	Rough Chrome Plated
- D	Polished Chrome Plated	Polished Chrome Plated	Polished Chrome Plated

## OPTIONAL EQUIPMENT: TO SELECT ADD SUFFIX

**1 1/2" / 3.8 cm VALVES**

- 10 With Model 2760 Brass Automatic Drain Valve
- 11 With Model 2765 Brass Adjustable Pressure Restricting Device
- 12 With Model 2770 Brass Restricting Disc.
- 14 With Model 4090 Double Female Adjustable Pressure Restricting Angle Valve
- 16 With Model 4010 Double Female Adjustable Pressure Regulating Angle Valve
- 18 With Model 4042 Double Female Pressure Regulating Angle Valve

**1 1/2" / 3.8 cm HOSE**

- 21 With Model 2915 Single Jacket Lined 300 PSI/20.7 bars Acceptance Pressure Test Polyflex Hose ◀ FM ▶ and U/L
- 23 With Model 2926 Single Jacket Lined 500 PSI/34.5 bars Acceptance Pressure Test PR-Superflex Hose ◀ FM ▶

- 24 With Model 2926 Single Jacket Lined 500 PSI/34.5 bars Acceptance Pressure Test PR-Superflex Hose ◀ FM ▶ and U/L

**1 1/2" / 3.8 cm COUPLING**

- 31 With Model 2930 -RL Rocker Lug Coupling
- 32 With Model 2941 Extruded Aluminum Coupling

**1 1/2" / 3.8 cm NOZZLE**

- 42 With Model 2960 Red Nylon Fog Nozzle
- 43 With Model 2972 Brass Fog Nozzle
- 44 With Model 2980 Red Nylon All-Fog Nozzle
- 45 With Model 2985 Brass All-Fog Nozzle
- 46 With Model 2993 Brass Fixed-Flow Nozzle



## 2500 SERIES

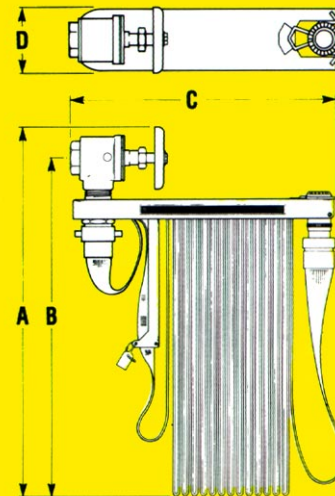

## OPTIONAL TYPES OF MOUNTING

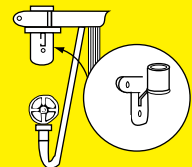

**-E WALL BRACKET**  
**FUNCTION:** Used to support hose rack assembly independent of standpipe.

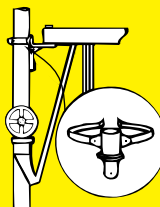

**-G PIPE CLAMP**  
**FUNCTION:** Used for external attachment to standpipe riser.