

# NIBCO®

AHEAD OF THE FLOW®

*The fast closing twin disks shut just as the reverse flow begins to eliminate or reduce the water hammer effect.*



## DOUBLE-DOOR CHECK VALVE

FIRE PROTECTION

### FEATURES

- 300 PSI Rating
- Wafer Connection
- UL Listed, FM Approved
- Size Range 2" - 16"
- EPDM Rubber Seat
- Spring Actuated
- Standard Stainless Steel Trim
- Epoxy Coated
- Bubble Tight Shut Off
- Ductile Iron Body



AHEAD OF THE FLOW®

**NIBCO INC.**  
**WORLD HEADQUARTERS**  
WEB: [www.nibco.com](http://www.nibco.com)

1516 MIDDLEBURY STREET  
ELKHART, IN 46516-4740  
USA

DOMESTIC CUSTOMER SERVICE  
PHONE: 800.234.0227  
FAX: 800.234.0557

INTERNATIONAL OFFICE  
PHONE: +1/574.295.3327  
FAX: +1/574.295.3455

# Wafer Style Twin Disk Ductile Iron Check Valve

Fire Protection Valve • Wafer Connection • Double-Door • EPDM Rubber Seat • Spring Actuated • Epoxy Coated

**300 PSI/20.6 Bar Non-Shock Cold Working Pressure**

UL/ULC LISTED •  
FM APPROVED • ANSI/NSF 372



**KW-990-E-LF**  
2" - 16"

## MATERIAL LIST

PART	SPECIFICATION
1. Valve Body	Ductile Iron ASTM A536 65-45-12
2. Disc (2)	ASTM 316 Stainless Steel
3. Stem (2)	ASTM 420 Stainless Steel
4. Spring	ASTM 304 Stainless Steel
5. Stem Seal (4)	EPDM
6. Rubber Seat	EPDM
7. Eyebolt	Carbon Steel Zinc Plated
8. Washer (4)	PTFE
9. Nameplate	Aluminum

## DIMENSIONS — WEIGHTS

VALVE SIZE	L	DΦ	D1Φ	D2Φ	WEIGHT	
inch mm	inch mm	inch mm	inch mm	inch mm	lbs kg	
2"	50 127	2.13 54	4.17 106	2.68 68	1.81 46	3.8 1.7
2½"	65 165	2.36 60	5.00 127	3.07 78	2.36 60	5.5 2.5
3"	80 203	2.24 57	5.28 134	4.02 102	2.76 70	6.3 2.9
4"	100 254	2.64 67	6.38 162	4.61 117	3.30 84	10.8 4.9
5"	125 318	3.27 83	7.64 194	5.71 145	4.53 115	16.2 7.3
6"	150 381	3.74 95	8.58 218	6.69 170	5.28 134	23.4 10.6
8"	200 508	5.00 127	10.9 276.8	8.9 226	7.24 184	41.5 18.8
10"	250 635	5.51 140	13.21 335.5	10.43 265	8.66 220	69.6 31.6
12"	300 762	7.13 181	15.96 405.5	12.2 310	10.24 260	112.5 51.0
14"	350 891	7.24 184	17.61 447.4	14.17 360	11.90 302	151.6 68.8
16"	400 1016	7.52 191	19.88 505	16.14 410	13.78 350	202.1 91.7

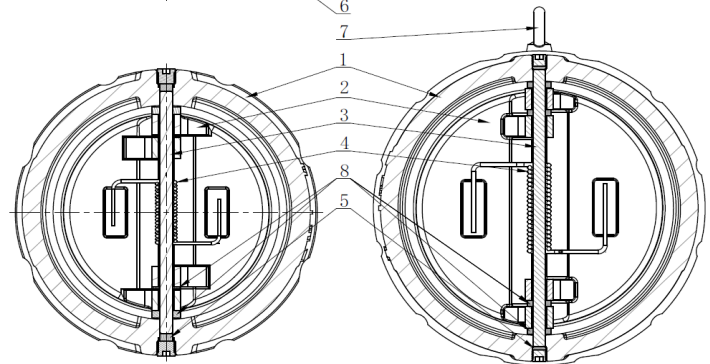
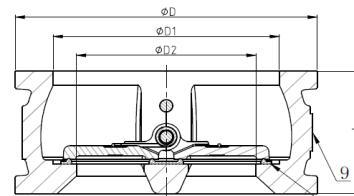

DN50-DN150

DN200-DN400

### Approvals and Certifications

- UL 312/ULC/ORD-C312 Listed
- NSF/ANSI 372
- UL/ULC Listed
- FM 1210 Approved

### WARNING

1. These are not to be used as steam valves
2. Valves are not to be used near a reciprocating air compressor
3. Install 5 pipe diameters minimum downstream from pump discharge or elbows to avoid flow turbulence. Flow straighteners may be required in extreme cases. NOTE: On pump discharge, the preferred check valves are in-line spring loaded disc hinge pin in the vertical position to insure proper operation.

### NOTES

1. Double door wafer style spring loaded check valve
2. Maximum operating pressure 300 PSI (20.6 bar)
3. Operating Temperature 32°F to 180°F (0°C to 82°C)
4. Design for use between flanges ASME B16.1 Class 125 or EN1092 PN16
5. Coating Fusion bonded epoxy in accordance with AWWA C550
6. Sizes DN200 - DN400 include an eyebolt for lifting
7. Applications: Fire protection, potable water, water distribution, etc.
8. Approved for vertical or horizontal installation

### Caution

- For horizontal flow applications, the valve must be installed with disc hinge pin in the vertical position to insure proper operation

Visit our website for the most current information.