

Fireriser® Indicator Post

Fig No.: IPO888

Materials List:

No	Name	Qty	Material
1	Locking Wrench	1	ASTM A126B
2	Operating Nut	1	ASTM B62
3	Hex Nut Screw	2	ASTM A105
4	Hex Nut	2	ASTM A105
5	Snap Ring	1	AISI 066
6	Target Carrier Nut	1	ASTM B62
7	Target	4	ASTM B108
8	Hex Cap Nut	4	ASTM A105
9	Window Glass	2	LEXAN-UM
10	Window Glass Gasket	2	PTFE
11	Hex Cap Screw	4	ASTM A105
12	Hex Nut	4	ASTM A105
13	Body	1	ASTM A536
14	Hex Cap Screw	6	ASTM A105
15	Hex Nut	6	ASTM A105
16	Base Flange	1	ASTM A126B
17	Hex Cap Screw	4	ASTM A105
18	Hex Nut	4	ASTM A105
19	Crane Coupling	1	ASTM A536
20	Cotter Pin	1	AISI 304
21	Stand Pipe	1	ASTM A53
22	Stem	1	AISI A1045
23	Plug	1	AISI 304
24	Cover	1	ASTM A126B
25	Cross Recessed Countersunk Head Screw	1	AISI 304
26	Locking Nose	1	ASTM 307 B

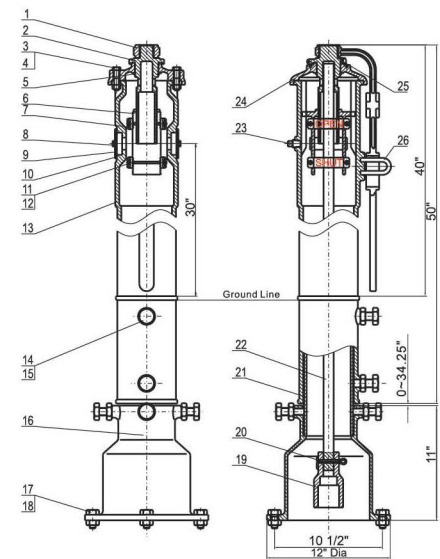

Field Adjustment:

1. Remove the top section from the top of the Indicator Post assembly.
2. Cut the required length off the bottom of the Standpipe for the Ground Line to match up with Standpipe Ground Line mark.
3. Set the "OPEN" and "SHUT" targets for the appropriate valve size.
4. Reattach the Top Section to the top of the Indicator Post assembly.
5. Design and dimensions are subject to change without notice.
6. Manufactured by FIVALCO LTD who have the UL and FM approvals.

Indicator Post Adjustment

Installation

NOTE: Ensure that the Non-rising Stem Gate Valve is in the fully open position before installing the Vertical Indicator Post.

1) Disassemble the Indicator Post

Take off the Locking Wrench(11). slide off the Top Section (20 together with the Operating Nut(19) and the square Stem(9) as well as the Crane Coupling(3) and ensure that all other accessories attached from the end of the Body(10) by loosening two Hex Cap screws(24) and Square Nut(23), slide off the Body(10) from the Standpipe(8) by loosening two Hex Cap Screws and Hex Nut, Loosen the two Hex Cap Screws and Hex Nut, Slide off the Standpipe(8) from the Base Flange(5).

2) Install the Base Flange and Standpipe

Attach the Base Flange(5) together with the Standpipe(8) to the Post Flange of the Non-rising Stem Gate Valve using the four Cap Screws(1) and Hex Nut(2).

3) Adjust the Grade Line Mark

Pull in and lower the Body(10) over the Standpipe(8) until the Ground Line Mark on the Body(10) is the same height as ground level. TIGHTEN THE Two Hex Cap Screws and Hex Nut.

4) Adjust the Square Stem

Lower the Stem(9) into Body (10) Standpipe(8) such that the Crane Coupling(13) fits over the Operating nut of the Nonrising Stem Gate Valve Ensure that the Stem(9) engages the Operating Nut(19) a minimum of 2 inches but no more than 4,5 inches, To check for correct engagement, the end of stem should be from 2 to 4, 5 inches below the top of the Body(10).

5) Adjust the Targets

Remove the Target Carrier Assembly(12+13+14) from inside the Body(10) by rotating the Operating Nut(19) counterclockwise. The Open Target(16) and Shut Target(not shown) are adjusted up or down on the Target Carrier Assembly(12+13+14) by pulling the middle section of the Target(Open and Shut) a small distance away from

the Target Carrier Assembly(12+13+14) and sliding the Target(Open and Shut) up or down as desired.

If the Non-Rising Stem Gate Valve is opened left: move the two Open Targets(16) to the very top of the Target Carrier Assembly(12+13+14). Locate the two Shut Targets(not shown) according to the Non-rising Stem Gate Valve size(stem) turning distance. If the Non-rising Stem Gate Valve is opened right: move the two Shut Targets(not shown) to the very top of the Target Carrier Assembly(12+13+14). Locate the two Open Targets(16) according to the Non-rising Stem Gate Valve size(stem) turning distance.

6) Final Assembly and Test

Insert the Target Carrier Assembly(12+13+14) back into the Top Section (20) by rotating the Operating Nut(19) clockwise, Rotate until the Open Target(16) is centered in the window of the window of the Body(10) which corresponds with the Non-rising Stem Gate Valve being in the open position. Lower the Top Section(20) with Target Carrier Assembly(12+13+14) onto the Body(10), assuring that the Stem(9) Engages with the Operating Nut(19) at least 2 inches but not more than 4.5 inches. Secure the Top Section(20) to the Body(10) by tightening the Cap Screw(24) and Square Nut(23) Close the Non-rising Stem Gate Valve and make sure that the Shut Target(not shown) is properly centered in the window of the Body(10) and adjust as necessary.

Maintenance

Oil the bearing in the Top Section(20) at least once per year by adding several drops of oil in the hole located on the top of the Operating Nut(19).